

# 電磁式/磁電式回転検出器 形状分類一覽

MP-900/9000 シリーズ(電磁式)

電源不要タイプ

MP-981/AP-981(磁電式)

低・中速対応型/防酸・防浸型

- A 検出可能周波数範囲
- B 検出歯車適合モジュール

MP-992 **A** 400~100,000 (Hz) **B** 1~3 **小型**

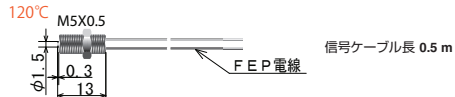

MP-950 **A** 300~35,000 (Hz) **B** 1~3

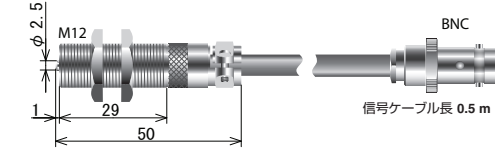

MP-962 **A** 400~35,000 (Hz) **B** 1~3

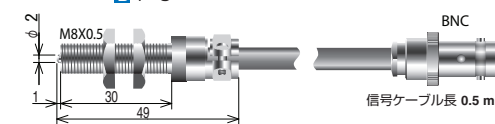

## 取付イメージ

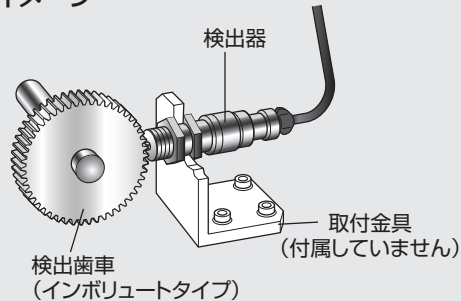

MP-936 **A** 300~35,000 (Hz) **B** 1~3 **耐環境**

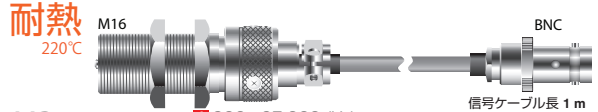

MP-935 **A** 300~35,000 (Hz) **B** 1~3 **1) 防油/耐熱**



MP-930 **A** 200~35,000 (Hz) **B** 1~3 **1) 防油**

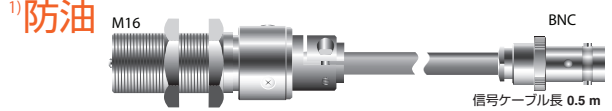

1) 日本電機工業会標準規格、JEM-1030-1983種類 防油型に適合

(普及型) MP-9100 **A** 200~35,000 (Hz) **B** 1~3 **汎用**

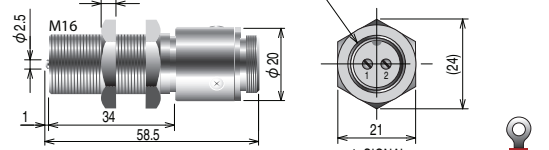

MP-911 **A** 200~35,000 (Hz) **B** 1~3

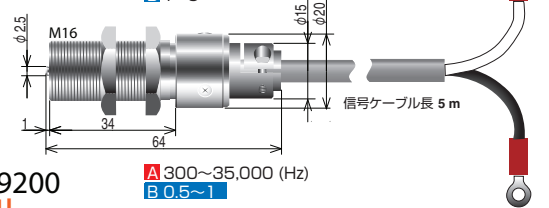

MP-9200 **A** 300~35,000 (Hz) **B** 0.5~1 **小モジュール**

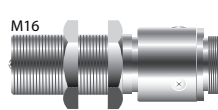

MP-963 **A** 45~15,000 (Hz) **B** 3~10 **中モジュール**

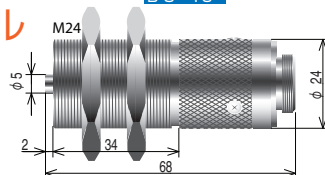

MP-9120 **A** 200~80,000 (Hz) **B** 1~3 **高速用**

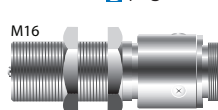

MP-981 **A** 1~20,000 (Hz) **B** 0.5~3 **磁電式 超低・中速対応**

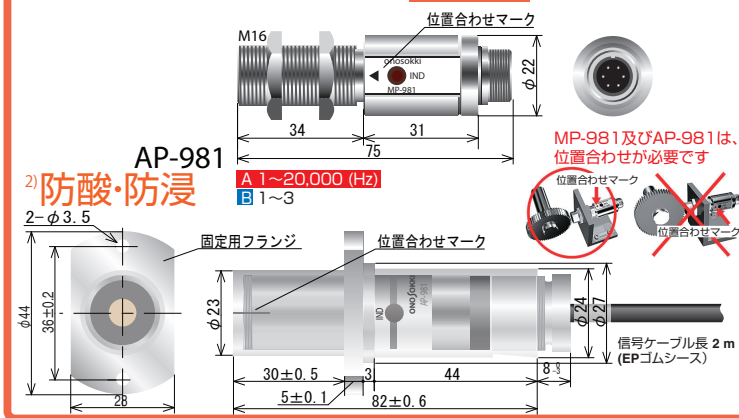

MP-981及びAP-981は、位置合わせが必要ですが、位置合わせマーク

2) 防酸・防浸 **A** 1~20,000 (Hz) **B** 1~3

2) JIS C 0920の電気機械器具及び配線材料の防水試験において、保護等級7 (表示記号: IPX7)に適合の防浸型。

MP-940A **A** 300~35,000 (Hz) **B** 1~3 **長体**

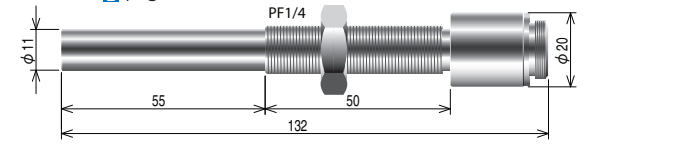

MP-954 **A** 300~35,000 (Hz) **B** 1~3

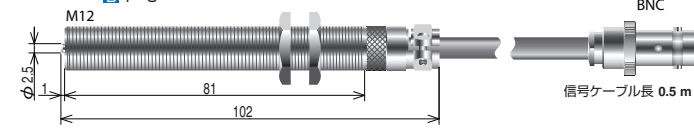

MP-001 MPシリーズ用 弊社標準検出歯車

