

**Discontinued**  
**(Reference only)**

# Personal FFT Analyzers

---

## CF-4210Z/4220Z



The jog/shuttle cursor, a wheel that combines the functions of a rotary knob and a shuttle cursor, provides easy menu window setup operation. The CF-4210Z/4220Z FFT analyzers can be used as OK/NG judgment machines on production lines simply by installing the comparator output card that is available as an option. The incorporation of a 6.4-inch LCD screen has enabled a considerable reduction in device weight (a reduction of 30% when compared with the previous models, CF-4210A/4220A).

**ONO SOKKI**

## Personal FFT Analyzers

# Lineup

The CF-4210Z and CF-4220Z are single-channel FFT analyzers that are equipped with a range of basic functions.

There are two models available: the standard CF-4210Z model and the more sophisticated CF-4220Z model that is provided with a microdot connector for direct sensor input and a floppy disk drive. The optional comparator function (CF-0460Z) enables the CF-4210Z/4220Z to be used as OK/NG judgment devices on production lines.



**CF-4210Z**  
Standard type

Built-in 6.4-inch  
LCD screen

Log/shuttle  
cursor for easy  
on-site operation

Light weight  
for easy carrying



**CF-4220Z**  
Direct sensor input, floppy disk drive  
provided as standard

1. 16-bit A/D conversion, 85 dB (typ) dynamic range
2. 1 kHz real-time analysis function provided as standard; 20 kHz available as an option (CF-0430)
3. OK/NG judgment is performed with respect to the power spectrum, 1/1 and 1/3 octave calculation results.
4. Up to a maximum of 16 blocks can be specified as the judgment area.
5. The comparison judgment method can be selected from five types: level, maximum value, area percentage, segment overall value and peak level.
6. The judgment results can be displayed on the LCD, or output using a relay contact.
7. Six types of functions such as Start, Start Comparison Judgment, and so forth can be freely used for the contact input.
8. NG data can be saved automatically to a floppy disk (CF-4220Z only).

Note: The CF-0460Z option is required for points 3. to 8. above.

# Features

*The comparator function demonstrates its power on production line OK/NG judgment applications.*

The comparator function is available as an option (CF-0460Z).

A judgment block is specified for the amplitude level, and then contact output used to perform OK/NG judgment of products on a production line.

The reference parameter used by the comparator is the rectangle defined by the upper and lower frequency and level limits (hereinafter referred to as "block"). Judgment is performed with respect to this block. The maximum number of blocks that can be specified is 16. The judgment level can be specified as (1) Upper limit value only, (2) Lower limit value only or (3) Both upper and lower limit values. The block's peak value or partial overall value can be used to perform comparison judgment.

With this judgment method, a judgment area block is specified on the power spectrum and one of five types of judgment methods selected for OK/NG judgment. Control can be performed via transmission through an RS-232C or other interface. A maximum of six types of relay contact input functions can be used, and control in combination with a sequencer can also be performed. The judgment results can be output via contact output to configure a system in combination with an inline tool such as a rotating warning light or alarm.

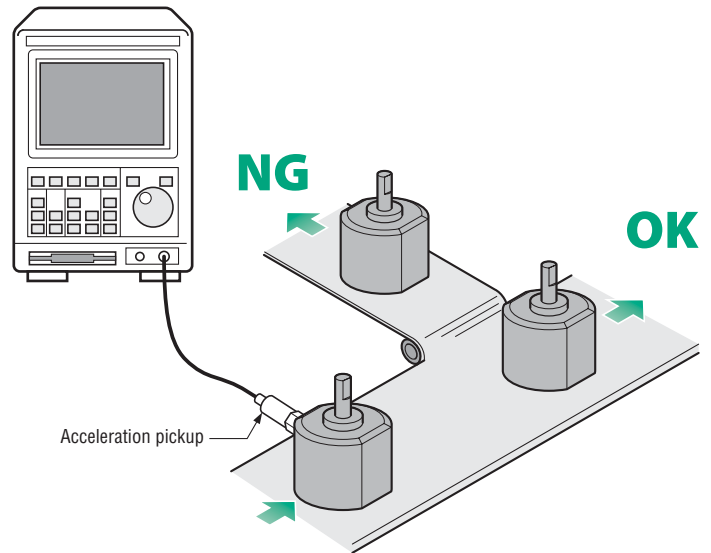

## Built-in contact input/output functions

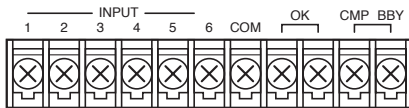

The comparator function enables output of the OK/NG results. In addition, it can be used as an external remote control function. By registering GPIB commands to each of the six contact input terminals, external control can be performed of such functions as start/stop, changing of the judgment parameters, and so forth.

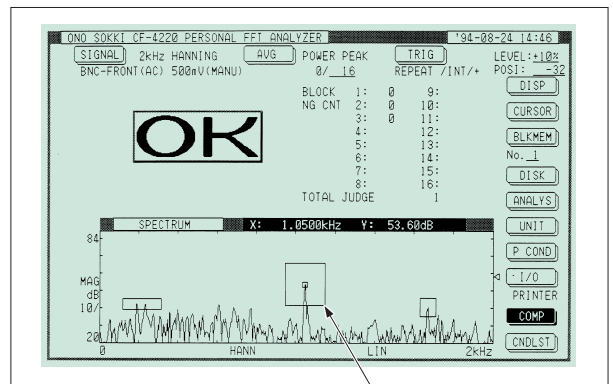

Comparator setup window

## Why judgment using FFT analysis is required

When evaluating product quality, it is not possible to judge phenomena such as sound frequency shifts and level variations, the effects on rotational frequency caused by motor eccentricity, or the variations in the tapping sound caused by the generation of cracks from the overall sound and vibration levels or from simply viewing the levels of specific frequency bands. For this type of evaluation, frequency analysis performed by an FFT analyzer is essential. If the CF-4210Z/4220Z models have been equipped with the CF-0460Z comparator function, a window specifying the frequency range and the upper and lower level limits can be set up (up to a maximum of 16 blocks can be specified for the judgment area) and the judgment method selected from the five types available: level, maximum value, area percentage, segment overall value and peak level.



# Applications

## Crack inspection of flexible pads, castings, metal plates, etc.

The tapping sound changes if there are any cracks present in homogeneous material. A microphone is used to measure the tapping sound. Frequency analysis is then performed and the results used to judge whether any cracks are present.

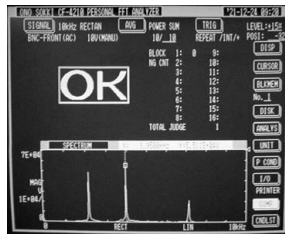
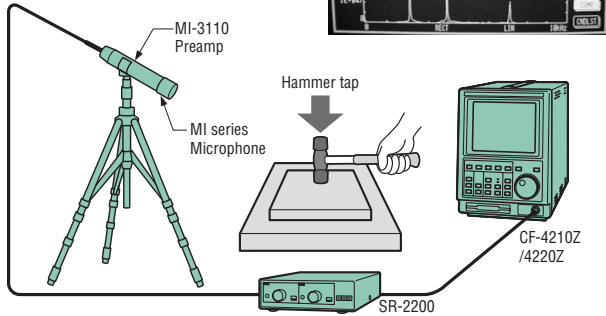

## Motor OK/NG judgment

The vibration frequency varies slightly if the motor shaft moves eccentrically or if an abnormality occurs. The spectrum area percentage with respect to the area defined by the specific frequency band and by its upper and lower limits is used for OK/NG judgment.

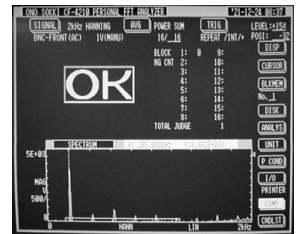
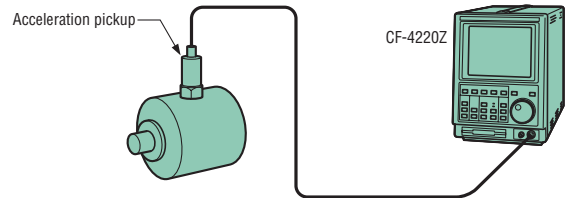

Note: An amplifier with a built-in acceleration pickup can be used for direct input.

## Judgment of mobile phone ring tones

Spectrum harmonics are used for the OK/NG judgment of the sound quality and level of mobile phone ring tones.

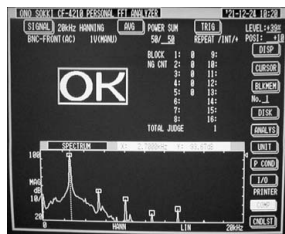
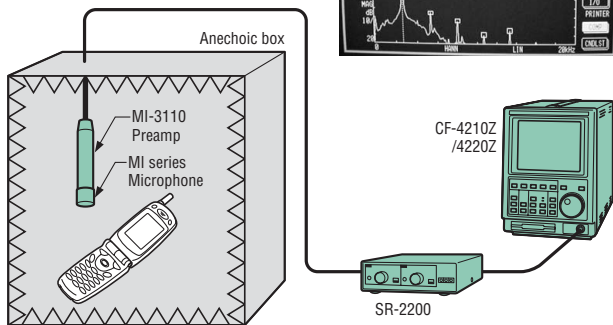

## Estimation of the resonance frequency of components

OK/NG judgment is performed from the power spectrum used for analysis when the components are shaken prior to assembly.

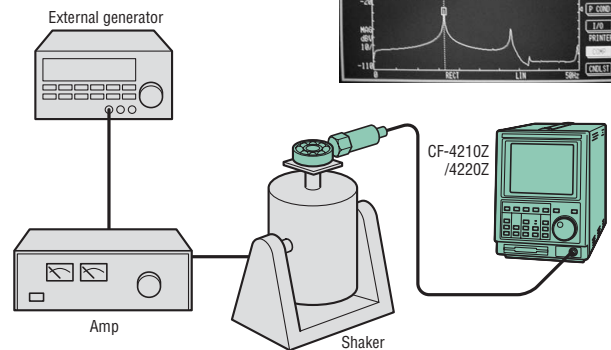

## Judgment of turbine noise level

The noise level generated by the turbo fan is held at peak-hold level. This level is then used for OK/NG judgment.

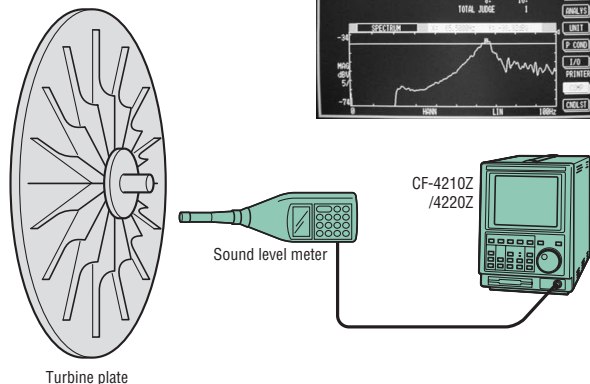

## Continuous monitoring of rotational fluctuations

The rotational fluctuations that occur when film or paper is being wound onto a roll result in bad production lots. The amplitude value of the amount of rotational fluctuation is monitored continuously.

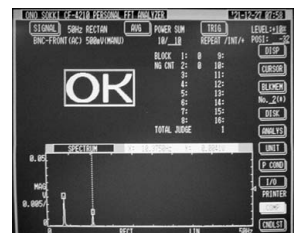
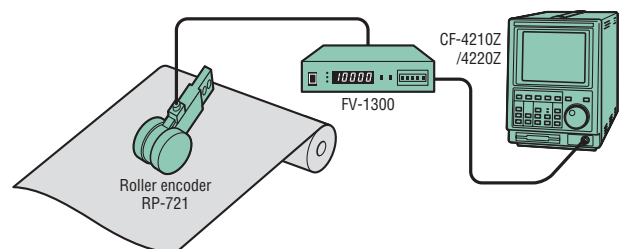

# System configuration

## External control

**Program sequencer**

OK/NG

Judgment display

OK NG

Input/output of judgment control

Comparator card Option (CF-0460Z)

## Vibration analysis

- Acceleration pickup: NP-3000 series



FDD (CF-4220Z)

Direct sensor input (CF-4220Z)

Voltage input (CF-4210Z/CF-4220Z)

## Sound analysis

- Microphone: MI-1211/1233/1431
- Microphone preamp: MI-3110



- 2-channel sensor amp: SR-2200



- Sound level meter: LA Series



## Vibration analysis

- Acceleration pickup: NP-2000 Series



- Charge amp: CH-1200



## Specifications

### Model variations

- CF-4210Z
- CF-4220Z (Direct sensor input function and floppy disk drive are provided.)

### Processing functions

Time-axis waveform, power spectrum, phase spectrum, 15 band 1/3 octave, 5 band 1/1 octave  
Probability density function, probability distribution function

### Input section

- Number of input channels: 1
- Input signal connectors: BNC connector (front and rear panels)  
Microdot connector (CF-4220Z only)

- Voltage range:  $\pm 10$  mV to  $\pm 50$  V, 12 ranges
- Dynamic range: 85 dB (typ)

### Analysis-related specifications

- Frequency ranges: 1 Hz to 40 kHz, 19 ranges
- Number of sampling points: 1024
- A/D resolution: 16-bit
- Frequency resolution: 1/400 of the frequency range
- Real-time analysis: 1 kHz standard (up to 20 kHz with the CF-0430 option)

### Trigger section

- Trigger modes: Free, repeat, single, one-shot
- Trigger source: Internal or external
- Trigger position: Specifiable in one-point increments within the range of -1024 to 1023 points
- Trigger level: Specifiable in  $\pm 1\%$  increments with respect to full scale of the voltage range

### Secondary processing calculation functions

Frequency axis differential/integral function, power spectrum density, partial overall, arithmetic calculation using memory waveforms

### Averaging processing

- Averaging modes  
Time axis waveform: Summation averaging  
Power spectrum: Summation averaging, exponential averaging, peak hold  
Phase spectrum: Summation averaging  
Octave: Summation averaging, exponential averaging, peak hold  
Probability density function: Summation averaging
- Number of averages: 1 to 8192

### 3.5-inch floppy disk drive (CF-4220Z only)

- Number: 1
- Format: MS-DOS format (1.2 M/1.44M)

### Display function

- Display: 6.4-inch liquid crystal display
- Waveform display mode: Single frame, dual frame, two overlaid frames
- Display functions: Y-axis auto scaling, Y-axis manual scaling, maximum value display function, search function,  $\Delta$  cursor function, list display, label function, setup display, etc.

### Memory section

- Screen data block memory: 30 frames maximum
- Panel condition setups: 4 types

### Comparator function (Option CF-0460Z)

- Functions that can be processed: Power spectrum, 15 band 1/3 octave, 5 band 1/1 octave
- Specifiable maximum number of blocks: 16
- Comparison judgment: Level, maximum value, area percentage, segment overall value, peak level
- Output of judgment results: When the judgment is OK: contact closed; when the judgment is NG: contact open. Please note however, that the OK/NG logic can be changed.  
Display of judgment results: The OK/NG judgment results can be displayed on the LCD.
- Automatic saving of NG data: When the judgment is NG, the data can be saved automatically to the screen data block memory or to a disk (in common with the auto store function)
- Relay contact input: Six functions such as Start, Start Comparison Judgment, and so forth can be freely used as the ON/OFF switch.
- Interface: RS-232C

### General specifications

- Power supply: 90 to 264 VAC (50/60 Hz)
- Power consumption: Approx. 50 VA
- Operating temperature range: 0 to  $+40^{\circ}\text{C}$
- Storage temperature range:  $-10$  to  $+60^{\circ}\text{C}$
- Outer dimensions: 200 (W) x 292 (H) x 396.4 (D) mm
- Weight: CF-4210Z; Approx. 4.4 kg  
CF-4220Z; Approx. 5.2 kg

### Options

- CF-0460Z: Comparator & RS-232C card
- CF-0430: High-speed real-time averaging
- CF-0431: Zoom software

Note: The minimum resolution is 10 mHz (when the span frequency is 4 Hz)

# Outer Dimensions

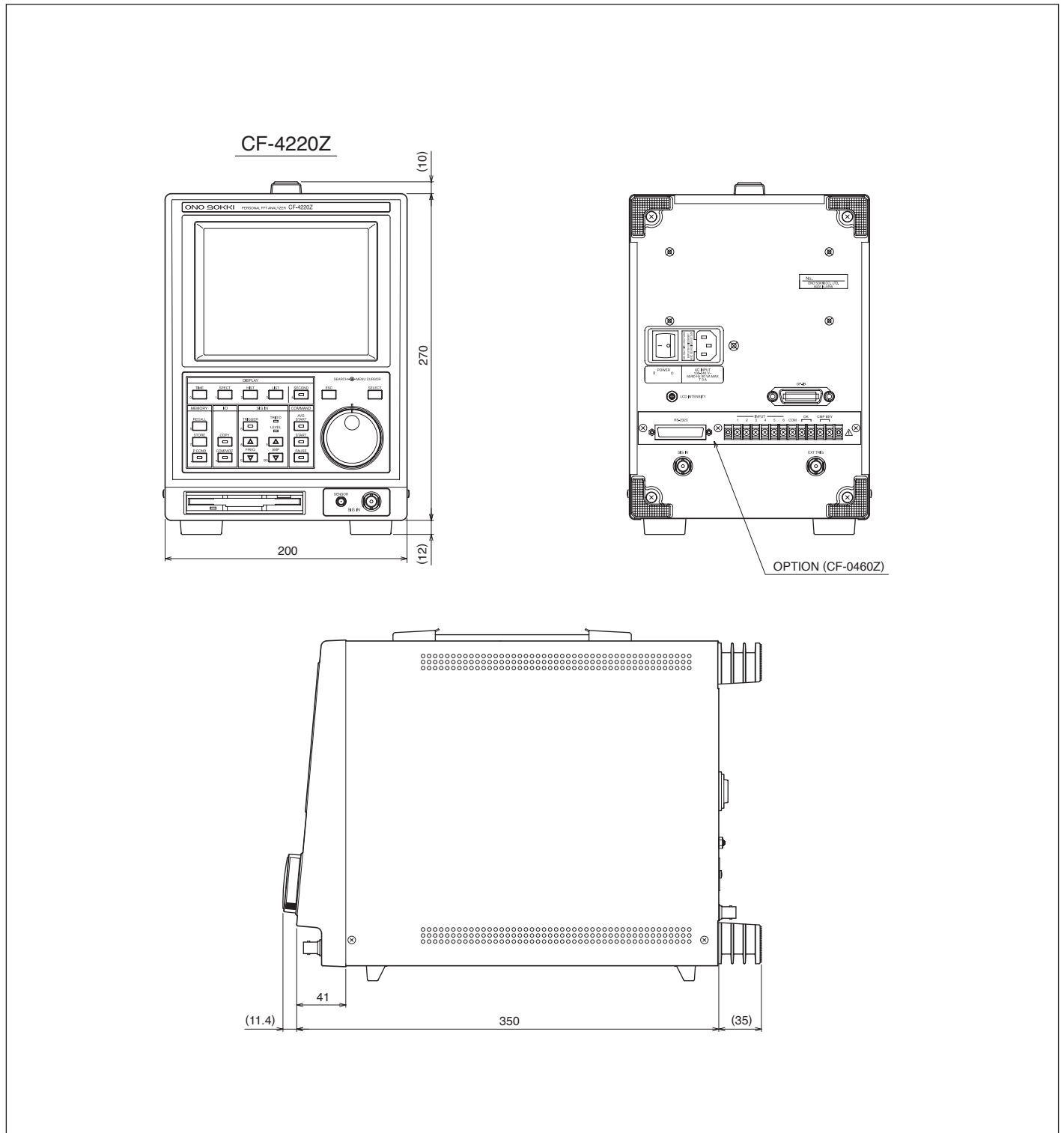

\* Outer appearance and specifications are subject to change without prior notice.

URL: <http://www.onosokki.co.jp/English/english.htm>

## ONO SOKKI

**U.S.A. & CANADA**  
 Ono Sokki Technology Inc.  
 2171 Executive Drive, Suite 400  
 Addison, IL. 60101 U.S.A.  
 Phone : 630-627-9700  
 Fax : 630-627-0004  
 URL : <http://www.onosokki.net>  
 E-mail : [info@onosokki.net](mailto:info@onosokki.net)

**THAILAND**  
 Ono Sokki (Thailand) Co., Ltd.  
 29/67 Moo 5 Tivanon Road, Pakkred,  
 Nonthaburi 11120, Thailand  
 Phone: 02-964-3884  
 Fax : 02-964-3887  
 E-mail: [osth\\_sales@onosokki.co.jp](mailto:osth_sales@onosokki.co.jp)

**P.R.CHINA**  
 Ono Sokki Beijing Office  
 Beijing Jing Guang Center 3510  
 Hu Jia Lou, Chao Yang Qu  
 Beijing P.R.C. 100020  
 Phone : 010-6597-3113  
 Fax : 010-6597-3114  
 E-mail : [onosokki@public.bta.net.ch](mailto:onosokki@public.bta.net.ch)

**WORLDWIDE**  
 Ono Sokki Co., Ltd.  
 1-16-1 Hakusan, Midori-ku,  
 Yokohama 226-8507, Japan  
 Phone : 045-935-3976  
 Fax : 045-930-1906  
 E-mail : [overseas@onosokki.co.jp](mailto:overseas@onosokki.co.jp)