

Utilizes the latest, all inclusive technology
in a high performance analyzer



Capable of providing measurement, analysis,
and reports all on one display

CF-3600 Portable FFT Analyzer

Discontinued
(Reference only)

ONO SOKKI



With its portability, the CF-3600 provides a less restricted and more convenient testing platform while still achieving high accuracy in vibration and noise measurement and analysis.

Introducing the CF-3600 Portable FFT Analyzer



Direct All in One

Easy Setup

The ease of transportation and setup make the CF-3600 ideal for work on the jobsite.

Simply plug the CF-3600 in and connect the sensors and it is ready to take measurements. The lightweight all-in-one construction makes using the unit at a jobsite easy and efficient. A battery backup ensures the data will never be lost in the event of a power loss.



Example of an on-board measurement setup

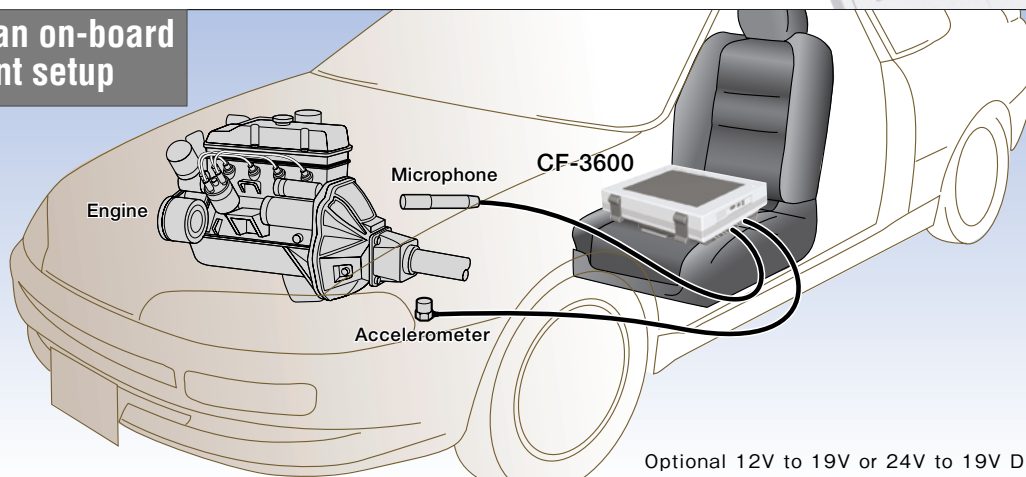

Optional 12V to 19V or 24V to 19V DC/DC converter

Direct Interface

The CF-3600 comes equipped with a 15 inch color touch panel monitor providing direct, intuitive operation and eliminates the need of a keyboard and mouse.

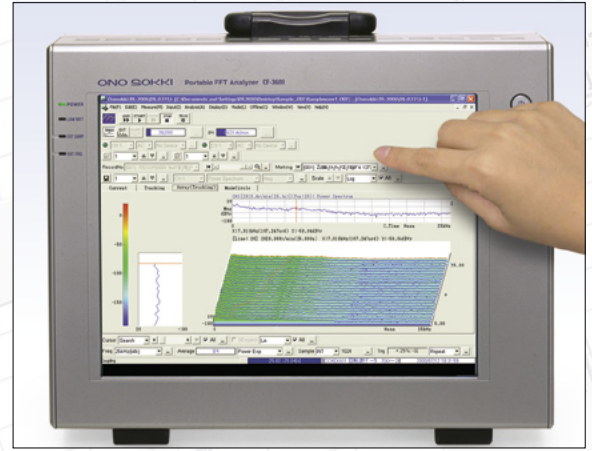

Various Analysis

Combining power with flexibility, the CF-3600 provides a wide array of analysis tools. These include:

- Noise and vibration measurements
- Tracking analysis provides the capability to evaluate rotating machines and engine dynamic characteristics.
- With realtime octave analysis, acoustical analysis is provided.
- Throughput disk function writes waveform data directly onto the built-in hard disk.
- Supports a wide range of application software.

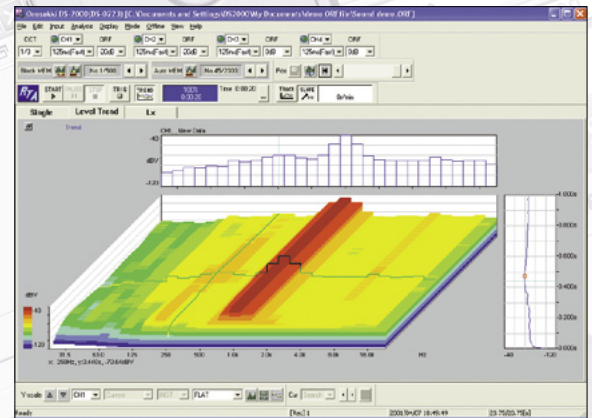

Smart Report

Creating reports at the jobsite becomes easy with the use of secondary processing software.

With spreadsheet software or graph creation software, users can easily create graphs and reports, and then export those files via the convenient USB and LAN interfaces to a wide array of peripheral equipment such as a printer.

Frequency Response Function Measurement

CF-3600T/CF-3600R

Resonance may cause not only chattering vibration in robots and machine tools but also vibration and noise in automobiles and home appliances. The most popular method for analyzing resonance is measurement of the frequency response function of the object in question, using an impulse hammer.

Excitation by an impulse hammer is the ideal choice at the jobsite measurement for troubleshooting because it reduces measuring time without the need to mount an exciter on the object. CF-3600 performs FFT signal analysis of 4 channels simultaneously with 40 kHz and 1/6400 frequency resolution.

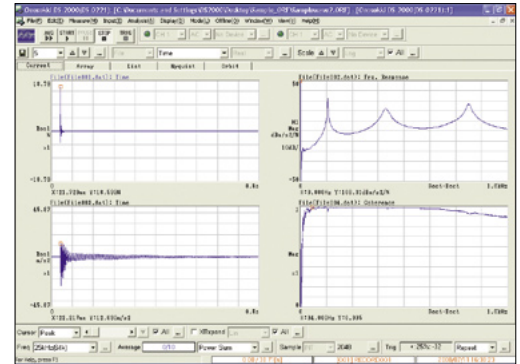

Sample Data displaying of Frequency Response Function

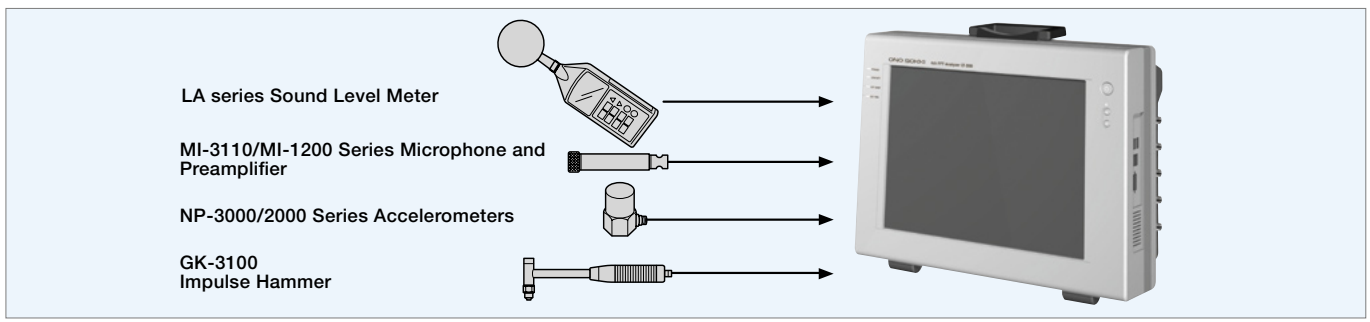

Throughput Disk Function

CF-3600T/CF-3600R

The ability to directly store the original signal waveform to the HDD of CF-3600 eliminates the needs to save to a data collector then retrieve it. This also allows you to store the data in non-degrading digital status. Use the data you recorded via the throughput disk function to analyze it on the CF-3600, as well as the offline analysis at PC on which DS-0221, DS-0222 or DS-0223 are installed. By changing the measurement and analysis conditions allows for flexible analysis.

Note: Please inquire separately regarding the licensed version of DS-0221, DS-0222, DS-0223, and other software.

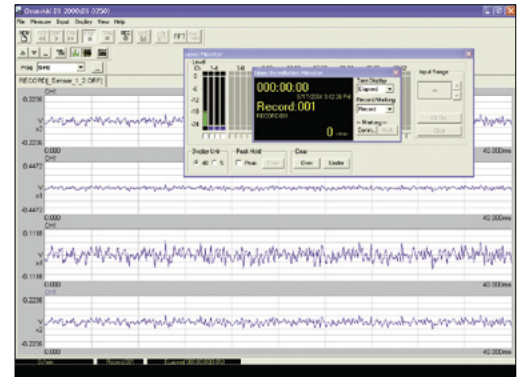

Sample Execution Displaying of Throughput Disk Function

Maximum recording time (minutes) *Recording time at AD conversion with 16-bit data only

f range	ch	
		4
40kHz		87 min
20kHz		175 min

File Export Function (Option: DS-0251)

Convert files saved by the throughput disk function in ORF format into WAV, TXT, DADiSP, MATLAB, UFF, and other formats, and export them to other applications for secondary analysis.

Tracking Analysis

CF-3600T

Rotating machinery such as engine, compressors and turbines etc. must cover wide range of rotating speed from very low to high speed. The most important issue is resonance which is caused by the rotational speed of the rotating machinery, which rotational frequency is same as the natural frequency of rotating machinery's components (e.g. axles, gears and brackets.).

In case of torsion vibration in large power generators and the like, resonance can cause serious accidents, creating vibration excitation energy that exceeds the tolerance of the machinery, destroying it.

Rotational tracking analysis is an effective method to identify the rotational speeds at which resonance occurs in rotating equipment, and which components generate vibration or noise, and to identify the orders (multipliers) of the rotating speed that generate vibration and noise.

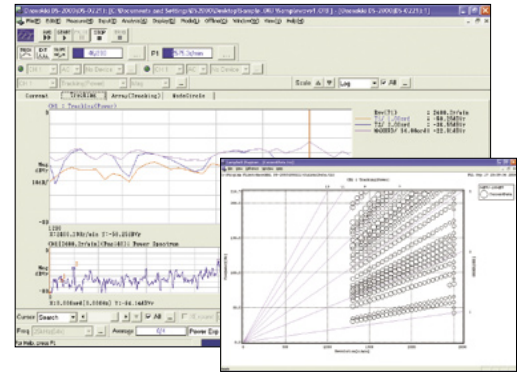

Sample Data Displaying of Tracking Analysis and Campbell Plot Function

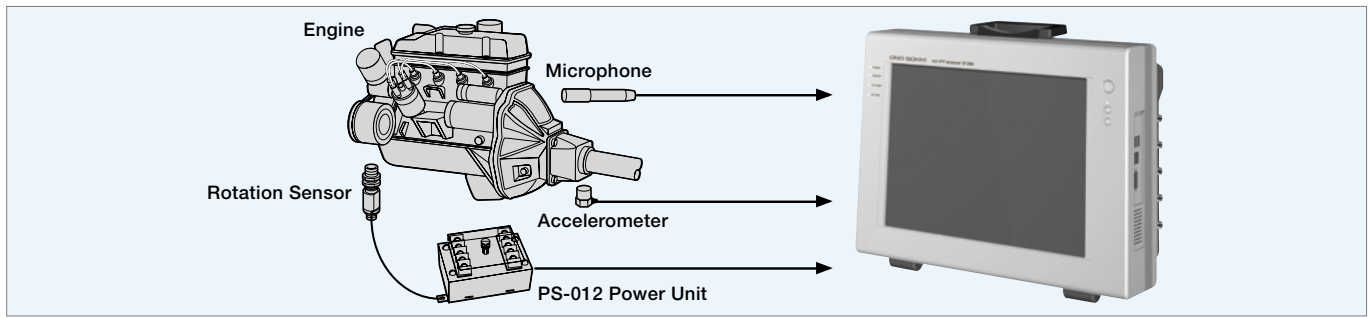

Real Time Octave Analysis

CF-3600R

In order to solve the noise problem, the frequency analysis is required. Especially octave analysis has long been used for frequency analysis. An octave is a frequency with ratio of 1:2 to the frequency that is, double the frequency. The human ear senses sounds in geometric progressions to the frequency. A series of octave bands based on 1 kHz has been standardized, and the acoustic pressure level of each band.

The octave band based on 1 kHz is called the 1/1 octave band, while the bands formed by dividing into third are called the 1/3 octave bands. CF-3600R performs real time octave analysis of 4 channels simultaneously.

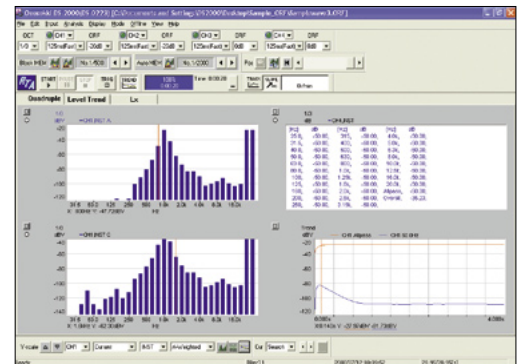

Sample Data Displaying of Octave Analysis

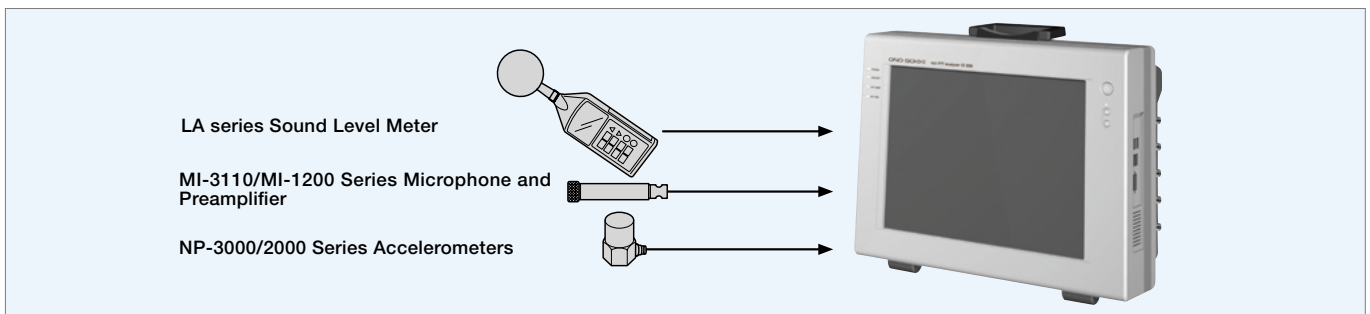

System Configuration

Various options and peripherals of CF-3600 can expand the possibilities of the flexible measurement and analysis.

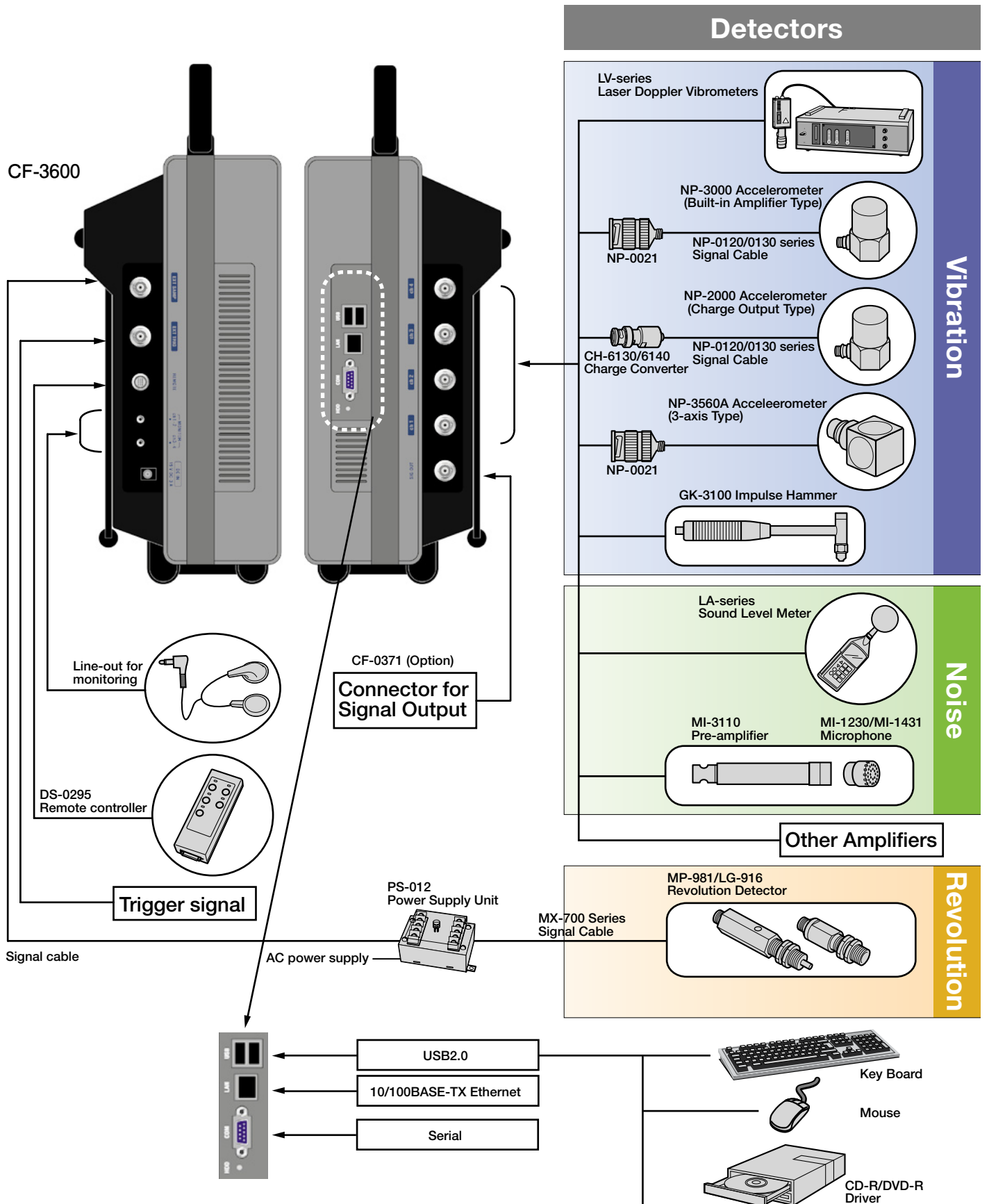

Please refer to the separated exclusive catalogue of each detectors and their peripherals in details.

Specification of CF-3600 FFT Analyzer

Basic Specification

■ Touch Panel Computer Section		■ General Specification	
CPU	VIA Eden 533 MHz	Dimension	410(W) x 314(H) x 150(D) mm *Excluding protrusion
Memory	256 MByte	Rated power voltage	19 VDC $\pm 5\%$
HDD	30 GB *Flash disk drive (4 GB) is optional.	Power consumption	Approx. 70 VA (at 100 VAC AC adaptor is used.)
Net Work	10BASE/100BASE-TX 1 pc.	Operating temperature	5 to 40°C (0 to 40°C when the optional flash disk drive is built-in.)
LCD	15 inch XGA 1024 x 768 dots	Storage temperature	-10 to 60°C
USB	USB2.0 x 2 pcs.	Weight	Approx. 10 kg
OS	Microsoft® Windows® XP Professional	Cooling fan	Not-provided (Natural air cooling)
		Treatment against instantaneous power failure	Battery charging circuit which battery pack (Lithium-ion secondary cell) is provided. *Operating time by battery is Max. 20 minutes.

■ Measurement Section		■ Panel LED Section	
FFT real time rate	40 kHz/4 channels	Power ON	Green
No. of input channel	4 channels	Low battery	Red *Flickering when the battery against power failure becomes low voltage.
External sampling input	1 channel, AC/DC, ± 0.5 to ± 10 V 0 to 85 kHz $\pm 10\%$ (-3 dB, with band pass filter) No. of P/R: 0.5 to 1024	External trigger signal	Green
External trigger input	1 channel, AC/DC, ± 0.5 to ± 10 V	External sampling signal	Green

Signal Input/Output Section

■ Signal Input Section		■ Signal Output Section (Option: CF-0371 1 Channel Signal Output Module)	
No. of channel	4 channels	No. of channel	1 channel
Type of input connector	BNC	Output connection	BNC connector
Configuration	Single ended	Output impedance	50 $\Omega \pm 10\%$
Impedance	1 M $\Omega \pm 0.5\%$, less than 100 pF	Amplitude of voltage	± 10 mv to ± 10 V
Coupling	DC or AC (less than -3 dB 0.55 Hz)	Frequency range	0 to 40 kHz
Current supply for sensor	2 mA/4 mA	Conversion rate	32, 44.1, 48, 51.2, 102.4 kHz etc.
Analogue filter	Acoustic A, B, C characteristic (provided as standard)	DA converter	20 bit 24 bit ($\Delta\Sigma$ type)
Amplitude range	-40 to +20 dBVrms (Every 10 dB step, 7 ranges)	Type of signal output	Sine, Swept sine, Random, Artificial random, Impulse, Octave band noise, Pink noise, Analogue output of time record data
Withstand input voltage	AC 70Vrms for one minutes (50 Hz)	FFT analysis length	64/128/256/512/1024/2048/4096
Frequency range	0 to 40 kHz	Voltage amplitude accuracy	Less than ± 0.5 dB
Sampling rate	32, 44.1, 48, 51.2, 64, 102.4 kHz etc.	Octave band filter	6th Butterworth (1/1, 1/3 octave)
Frequency accuracy	Less than ± 50 ppm	Octave band noise	1/1 oct - 1 Hz to 16 kHz, 15 bands 1/3 oct - 0.5 Hz to 20 kHz, 47 bands
AD converter	24 bit ($\Delta\Sigma$ type)	Pink filter	Analogue filter -3 dB/OCT ± 1.0 dB (at 20 Hz to 20 kHz)
Dynamic range	100 dB	Output mode	Continuous/Single burst/Continuous burst
Full scale accuracy	Less than ± 0.1 dB (at 1kHz)	Taper function	Provided (1 ms to 32 S) Not available when burst function is set at ON.
Cross talk	Less than -90 dB (at 1 kHz)	Limitation of frequency range	Not effective for swept sine, artificial random, impulse signal at the frequency range at 8 kHz, 1.6 kHz, 320 Hz, 64 Hz.
Gain accuracy between channels	Less than ± 0.3 dB		
Phase accuracy between channels	Less than 0.5 degree (DC to 20 Hz) Less than 1 degree (20 to 40 kHz)		
Digital filter	Anti-aliasing filter		

■ Line-out for Monitoring Section	
2.5 ϕ mini-stereo jack x 2 pcs. are used (for CH1/2 and CH3/4).	
1 Vrms $\pm 1.0\%$ /FS (full scale) against input voltage range (non-load 1 M Ω)	

Accessories Section

■ Accessories		■ AC Adaptor Specification	
Instruction manual	1 copy	Rated input voltage	100 to 240 VAC
AC adaptor	1 pc.	Frequency	50 to 60 Hz
Power cable for AC adaptor	1 pc.	Output voltage	19 VDC
Remote control box with cable	1 pc.	Output current	4 A
Front panel protection cover	1 pc.		
Battery pack	1 pc. (Lithium-ion secondary cell, model DR202B)		

■ Remote Controller Specification	
External dimension	45(W) x 25(H) x 117(D) mm *Excluding protrusion
No. of operation button	5 pcs. (START/STOP/F1/F2/F3) *User's defined key at F1/F2/F3
LED	5 pcs., Green LED (Displaying the status)

CF-3600T

Tracking Analysis Set

■ Configuration

- Main unit of CF-3600
- FFT Analysis Software
- Tracking Analysis Software
- Throughput Disk Function Software
- Standard Accessories
(AC adaptor, Battery pack, Front panel protection cover, Instruction manual)

CF-3600R

Real-time Octave Analysis Set

■ Configuration

- Main unit of CF-3600
- FFT Analysis Software
- 1/1, 1/3 Real Time Octave Analysis Software
- Throughput Disk Function Software
- Standard Accessories
(AC adaptor, Battery pack, Front panel protection cover, Instruction manual)

■ Optional Hardware

- CF-0371 1 channel signal output module
CC-0036 Hard carrying case

■ Optional Software

- DS-0221 FFT Analysis
DS-0222 Tracking Analysis
DS-0223 1/1, 1/3 Real Time Octave Analysis
DS-0244 Campbell Plot Function * DS-0222 is required in order to activate DS-0244.
DS-0250 Throughput Disk Function
DS-0251 File Export Function * DS-0250 is required in order to activate DS-0251.
(Applicable for WAV, TXT, DADiSP, MATLAB, UFF)

External drawing

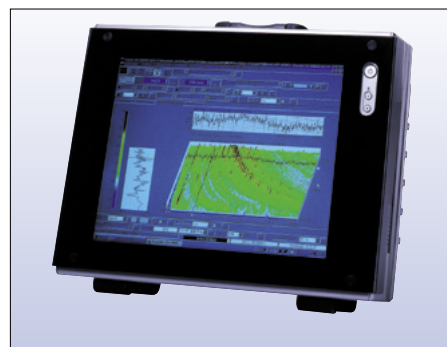
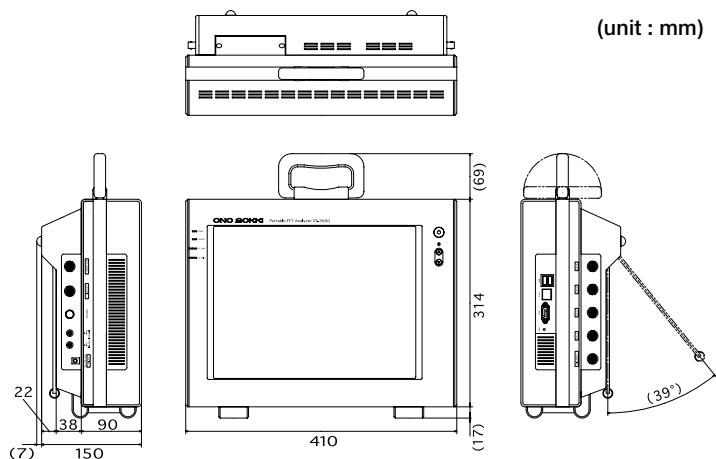

LCD is covered by protection cover (standard accessory).

• Windows® is a registered trademark of Microsoft Corporation in the United States and/or countries.
All other company names and product names used in this brochure are the product names or registered trademarks of their respective holders.
*Outer appearance and specifications are subject to change without prior notice.

ONO SOKKI

URL: <http://www.onosokki.co.jp/English/english.htm>

U.S.A & CANADA

Ono Sokki Technology Inc.
2171 Executive, Drive, Suite 400
Addison, IL. 60101 U.S.A
Phone : 630-627-9700
Fax : 630-627-0004
URL : <http://www.onosokki.net>
E-mail : info@onosokki.net

P.R.CHINA

Ono Sokki Beijing Office
Beijing Jing Guang Center 3510
Hu Jia Lou, Chao Yang Qu
Beijing P.R.C. 100020
Phone : 010-6597-3113
Fax : 010-6597-3114
E-mail : onosokki@public.bta.net.cn

WORLDWIDE

Ono Sokki Co., Ltd.
1-16-1 Hakusan, Midori-ku,
Yokohama 226-8507, Japan
Phone : 045-935-3976
Fax : 045-930-1906
E-mail : overseas@onosokki.co.jp