

**Discontinued**  
(Reference only)

# Stepping Motor Station PV-7300 System

*A single system can measure all seven of the characteristics important in a stepping motor, namely the  $\theta$ -T characteristic, holding torque, detent torque, pull-in torque, pull-out torque, damping characteristic, and angular accuracy.*

*With just a click of the start button, automatic measurement is started and the results of measurement displayed in a graph.*

*The Stepping Motor Station can be used regardless of the motor driving method and number of phases. It can also be used for the evaluation of motors and motor drivers.*

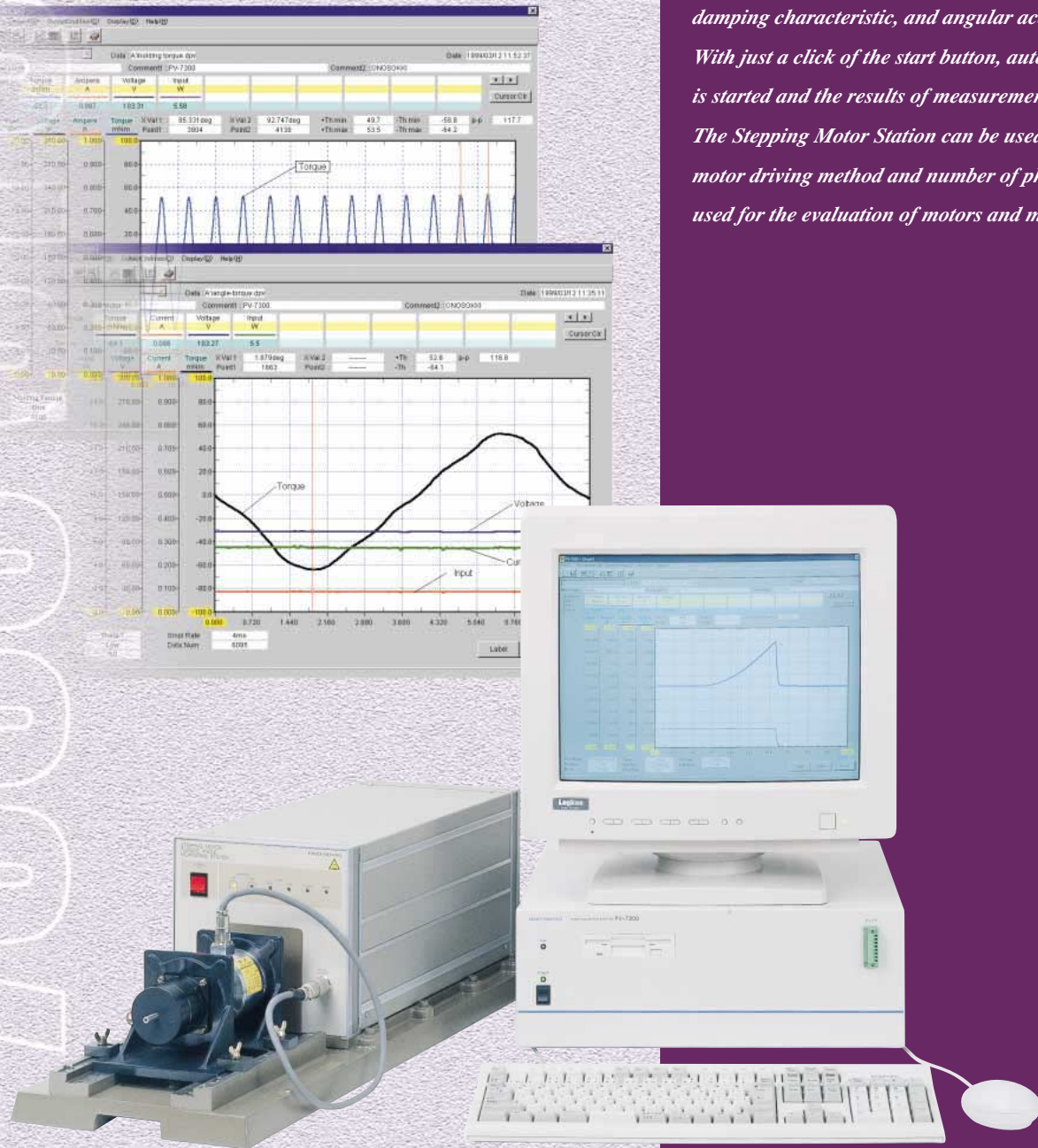

**NEW**

**ONO SOKKI**

# Motor Performance Determined from Torque and Angle

The Stepping Motor Station, PV-7300 system measures many kinds of characteristics related to torque and angle for comprehensive motor evaluation. Its automatic measurement provides both labor-saving and time-saving benefits.

## ■ RK series angle detector

Besides the RK series (dual-shaft), customer-prepared laser encoders (single-shaft) and general-purpose encoder can also be used. When a single-shaft motor is positioned as shown in the figure, a dual-shaft detector can be used to measure the angle.

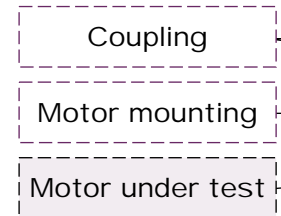

## Features

### 1. Measures 7 characteristics concerned with torque and angle

Static torque characteristics:  $\theta$ -T, holding torque, detent torque

Dynamic torque characteristics: Pull-in torque, pull-out torque

Angular characteristics: Damping characteristics, and angular accuracy

### 2. Precise torque measurement

The magnetic phase differential system achieves torque data with  $\pm 0.5\%$  accuracy.

### 3. Support of high-resolution angle sensor

The PV-7300 system supports the RK Series of angle detectors, which achieve a resolution equivalent to 100 000 P/R (pulses/revolution). It also supports laser encoders<sup>1</sup>, achieving even more precise measurement of angular accuracy and damping characteristic.

### 4. Efficiency computing function

If a power meter is combined, data on the motor's efficiency can be obtained by inputting power data to the analog signal.

### 5. User-friendliness using Windows-based software

The station is based on mouse operation and pull-down menus, both of which are familiar from personal computers. Thus, you will be able to use the system in no time.

### 6. Measures for various types of stepping motors

The torque detector can be selected from a big lineup of models ranging from 0.01 to 20 N·m. The system can be used with various motor drivers owing to the high versatility of the clock pulse output.

Note 1: A combination of data from Canon's K1 and U16 laser encoders is supported.

## Configuration / Block Diagram

### PK series torque detector

A torque detector, which comes with a brake, a driving motor, and guide rails for mounting the motor and which operates according to the signal from PV-7300. Select a detector according to your torque capacity requirements.

Options  
Prepared by customer

CRT

### PV-7300 torque angle meter

Outputs command signals according to the measured item set, and also outputs a stepping clock signal. The torque angle meter computes both torque & angle, measures analog data, displays the results in graphs, and outputs data.

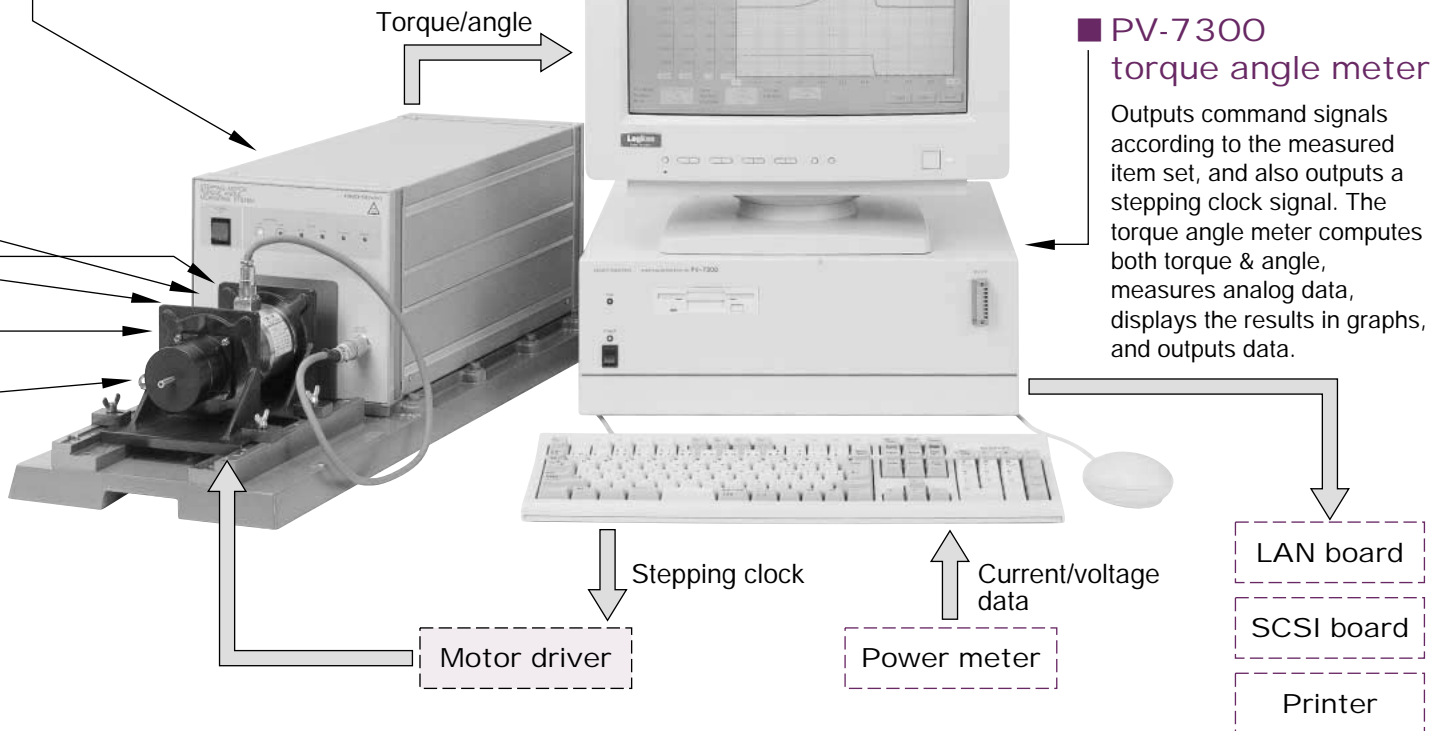

## User-friendly Properties

### ● Clock pulse output

Supports motor drivers using common pulse methods (e.g., rotational direction signals and clock pulses) as well as motor drivers using independent pulse methods (e.g., CW input and CCW input). This allows the PV-7300 to be used regardless of the motor driver's driving method and number of phases. A maximum output of 800 kHz is possible.

### ● Evaluation of motor and motor driver on a graph display

A stepping motor exhibits different characteristics depending on the driver used with it. By overlaying graphs of the motor performance, the PV-7300 clearly indicates which driving method is suitable for the motor and which motor agrees with the driver.

### ● Data output

Measurement conditions and measured data can be easily saved into the built-in FDD and HDD. A hard copy of the characteristic graphs can be output from a color printer, and measured data can be output to a file in text format to be processed on a spreadsheet or other program.

## Measurement Modes

For the measurements of 3 to 7, an angle detector is necessary.

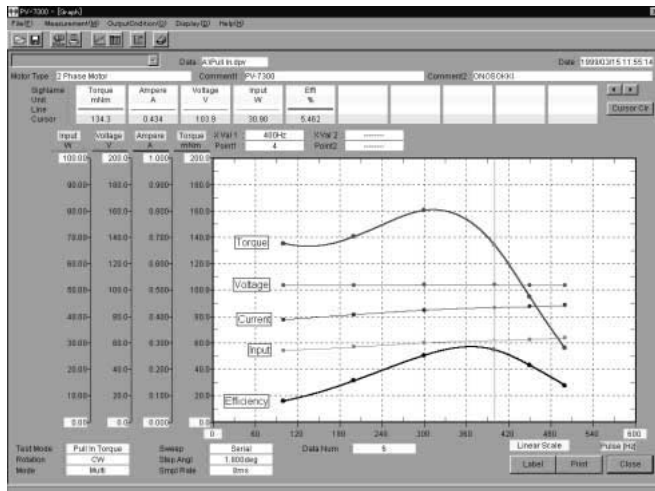

### 1. Pull-in torque

Up to 50 points can be set for the frequency, while the output clock can range from 10 Hz to 800 kHz. This mode measures the synchronous rotating torque while automatically changing the braking force and output clock. Data are plotted on a graph using spline interpolation between data points.

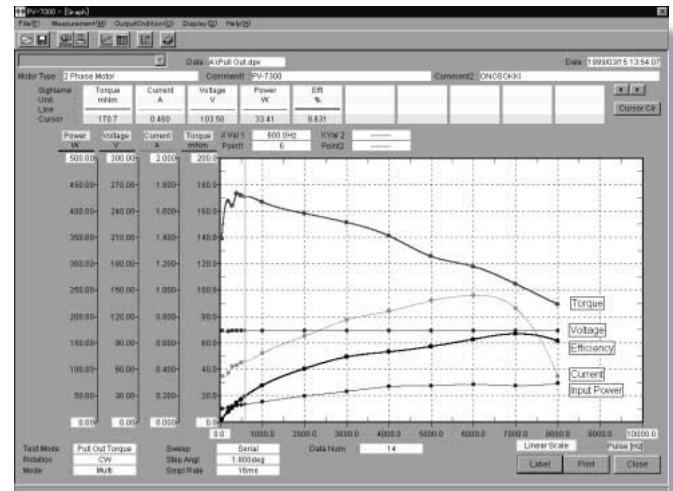

### 2. Pull-out torque

The same number of frequency points and the clock output range as that for pull-in torque can be set for pull-out torque. A slow-up setting for the output clock, in which the clock is made faster gradually, is also provided. Data are plotted on a graph using spline interpolation between data points. The pull-in torque and pull-out torque curves can be displayed on the same screen.

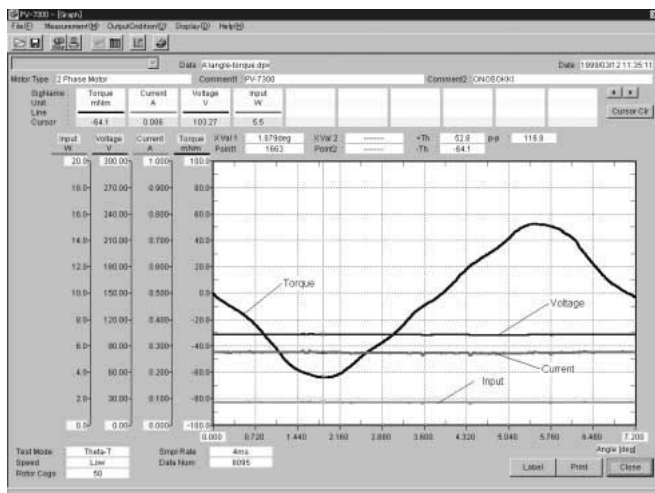

### 3. Angle-torque characteristics ( $\theta$ -T)

This mode measures the specified ranges of angle and torque. Measurement is performed on an excited motor without pulse input, with its shaft geared inside the PK detector and rotated at an extremely slow 0.06 rpm approximately. Data obtained for an angle of up to the 90° can be displayed. The data display can be centered at the stable point.

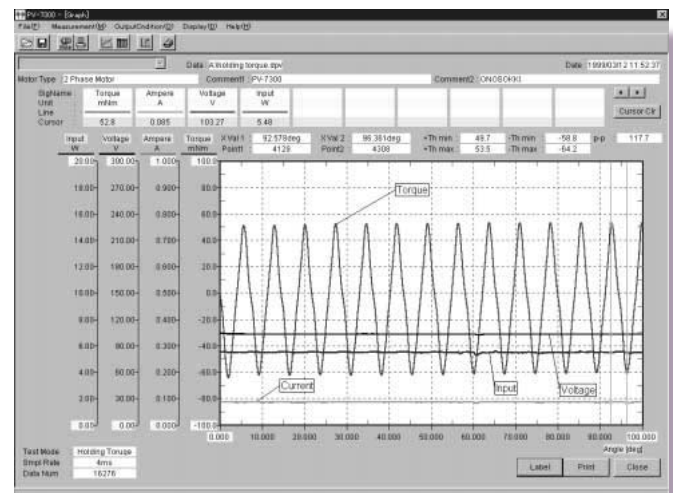

### 4. Holding torque

(Maximum static torque during excitation) This mode measures angle and torque over one entire rotation (360°) while the motor is excited. The PK detector measures the torque while rotating the shaft at a slow 1 rpm. Dispersion within one rotation can be understood from the display of the maximum and minimum values of the positive and negative peaks.

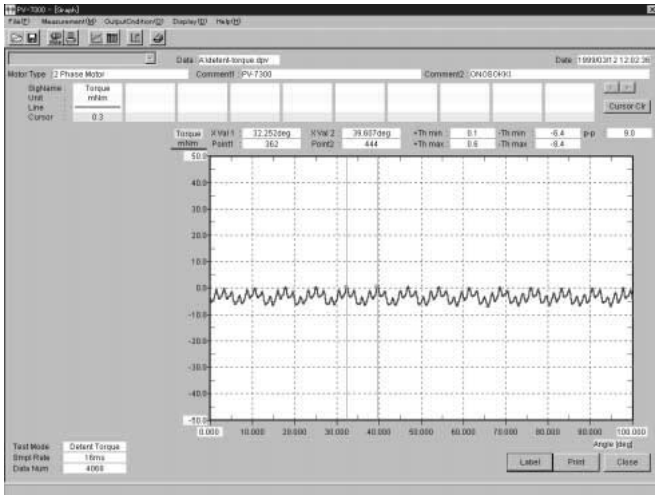

## 5. Detent torque (Holding torque without excitation)

This mode measures angle and torque over one entire rotation (360°) while motor excitation is OFF. The mode is used to measure both the PM and HB stepping motors which have permanent magnets on their rotors. The PK detector measures the torque while rotating the shaft at a slow 1 rpm. Dispersion within one rotation can be understood from the display of the maximum and minimum values of the positive and negative peaks.



## 6. Damping characteristics (Step-response characteristic)

This mode measures transient response characteristics using an angle detector. The sampling time can be set anywhere in the range of 10 μs to 1 ms, in order to capture even rapid variations. The overshoot angle and settling time over one step to the PV-7300's pulse output can be read from the graph display. Measurement is also possible with braking force applied by PK series detector.

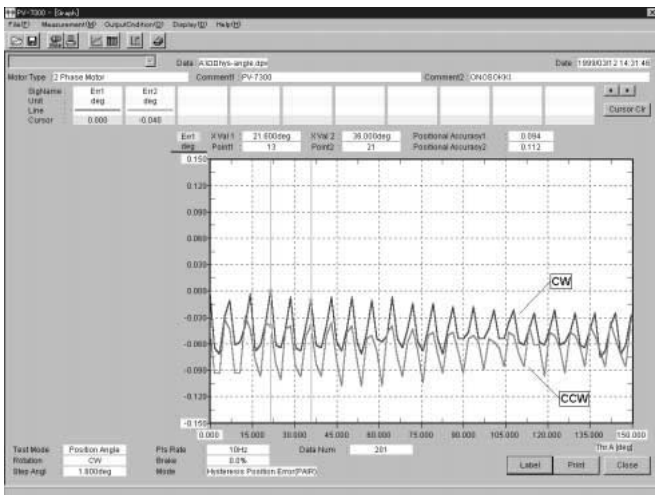

## 7. Position angle (Angular accuracy)

In this mode, three items are measured: stationary angle error, step angle error, and hysteresis error. Resolution and accuracy depend on the angle detector used. Once measurement is complete, the error values are computed automatically and displayed. If an RK series detector is used, measurement with an accuracy of within  $\pm 0.01^\circ$  is possible. (The graph display example shows hysteresis error.)

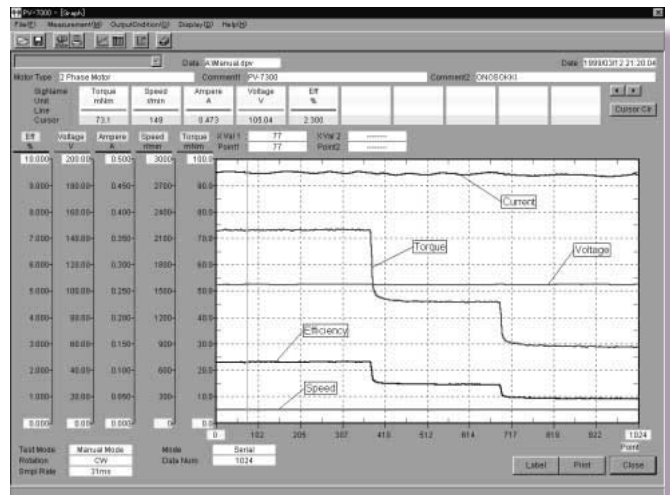

## 8. Manual mode

This mode achieves continuous operation and measurement according to how you have set the motor driving output clock and braking force. Each of the specified values can be changed during operation. This mode is effective for precise efficiency measurement.

# PV-7300 System Specifications

## Specifications

### ● PV-7300 Torque Angle Meter

Measurements	Angle, torque, and analog input signal
Measurement accuracy	Torque: $\pm 0.5\%$ of full scale
	Angle: $\pm 0.01^\circ$ when the RK series angle detector is used.
Sampling time	4 ms to 1 s
Measurement modes	$\theta$ -T characteristics, holding torque, detent torque, pull-in torque, pull-out torque, damping characteristic, angle error
Signal input section	Torque: Output signal from a phase-differential detector
	Angle:

	①	②	③
Angle	From RK series detector	From Cannon K1 laser encoder + multiplier IU16	Incremental TTL or open collector signal with $90^\circ$ phase difference
Input impedance	Approx. 100 $\Omega$	Approx. 150 $\Omega$	Approx. 1k $\Omega$
Input frequency range	0 to 250 kHz	0 to 5 MHz	
Input signal amplitude range	Approx. 11 App	3 to 5.25 V (high level); 0 to 1.4 V (low level)	

Analog:  $\pm 10$  V DC, 4 channels

Motor driver interface	Output configuration: Open collector Output signal: Rotational direction signal, clock pulse Excitation on/off command signal Power supply output for interface (switched between 5 V and 12 V)
Display	CRT (option)
Storage of measurement data	Hard disk or floppy disk
Storage of measurement conditions	Hard disk or floppy disk
Operating temperature	0 to 40°C
Power requirements	100 to 240 V AC $\pm 10\%$ , 50/60 Hz
Power consumption	100 VA or less (at 100 V AC)
Dimensions	420 (W) $\times$ 149 (H) $\times$ 449.5 (D) mm excluding protrusions
Weight	Approx. 10 kg
Accessories	Keyboard, mouse, power supply cable, three signal cables, connector for motor driver signal output, PV-7300 application software, and Windows 98.

### ● PK Series Torque Detectors

Model	Detector capacity	Moment of inertia	Detector shaft diameter
PK-102	10mN·m	10gcm <sup>2</sup>	3mm
PK-202	20mN·m	10gcm <sup>2</sup>	3mm
PK-502	50mN·m	14gcm <sup>2</sup>	5mm
PK-103	100mN·m	27gcm <sup>2</sup>	5mm
PK-203	200mN·m	27gcm <sup>2</sup>	5mm
PK-503	500mN·m	147gcm <sup>2</sup>	8mm
PK-104	1N·m	147gcm <sup>2</sup>	8mm
PK-204	2N·m	371gcm <sup>2</sup>	8mm
PK-504	5N·m	1.7kgcm <sup>2</sup>	14mm
PK-105	10N·m	6.6kgcm <sup>2</sup>	14mm
PK-205	20N·m	6.6kgcm <sup>2</sup>	14mm

Rpm measurement range: 0 to 3000 rpm

Torque detection method: Magnetic phase-differential system

Torque measurement accuracy:  $\pm 0.5\%$  of full scale

Internal drive speed: 0.06 rpm or 1 rpm (selectable)

Braking: Powder brake system

Operating temperature: 0 to 40°C

Power requirements: 100 to 240 V AC  $\pm 10\%$ , 50/60 Hz

Power consumption, dimensions, weight: Differ for each model

Accessories: A power supply cable

## ● RK Series Angle Detectors

Model	RK-820	RK-830
Detection method	Optical phase-differential system	Optical phase-differential system
Shaft shape	Dual shaft	Dual shaft
Diameter of detector shaft	5 mm for both ends	12 mm for motor side 8 mm for PK side
Moment of inertia	17 gcm <sup>2</sup>	29 gcm <sup>2</sup>
Allowable torque*	50 mN·m or less	500mN·m or less

\* Upper limit of torque when an angle detector is used between the torque detector and motor. Consult us if the torque for either model exceeds the specified limit.

Angle detection accuracy:  $\pm 0.01^\circ$

Angular resolution: 5000 P/R; however, this is multiplied to 100 000 P/R within the PV-7300.

Operating temperature: 0 to 40°C

Power requirements: Supplied from the PV-7300

Accessories: L-shaped mounting fixture and signal cable

Note: No couplings are supplied.

## ■ Options

### ● L-shaped fixture for mounting motor

Machined and unmachined fixtures are available. Please specify the dimensions of the A, B and C below for machined fixtures.

The unmachined fixture has a predrilled hole (3 mm in diameter) in the center.

(Unit: mm)

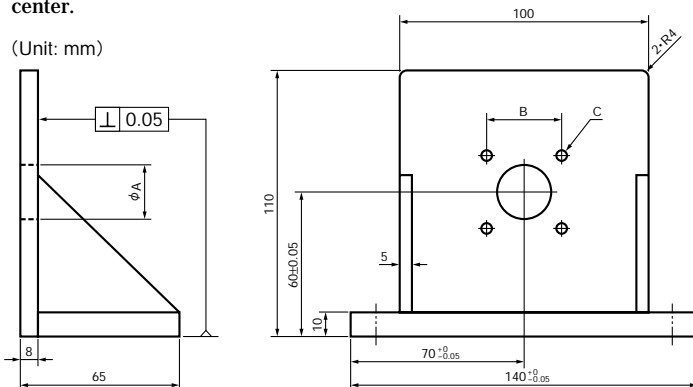

### ● Couplings

Couplings are used as links between the motor, angle detector, and torque detector. For torque measurement, use bellows couplings, which have a high level of rigidity in rotational directions. For angle measurement, use helical couplings. We can supply couplings for the specified motor shaft diameter.

### ● Monitor

Use a monitor that supports analog RGB, 1024 × 768 pixels, and capable of handling 256 colors. (Comes with a 15-pin mini D-sub connector for the PV-7300 side.)

### ● LAN board

Please consult us for our recommendations.

### ● SCSI board

Please consult us for our recommendations.

### ● Printer

A Windows 98-compatible printer can be used. The printer is used to produce hard copies of graphs, tables, and measurement conditions setting. This printer has a Centronics-compatible 8-bit parallel port (and comes with a 25-pin D-sub connector on PV-7300 side).

External view

(Unit : mm)

● PV-7300

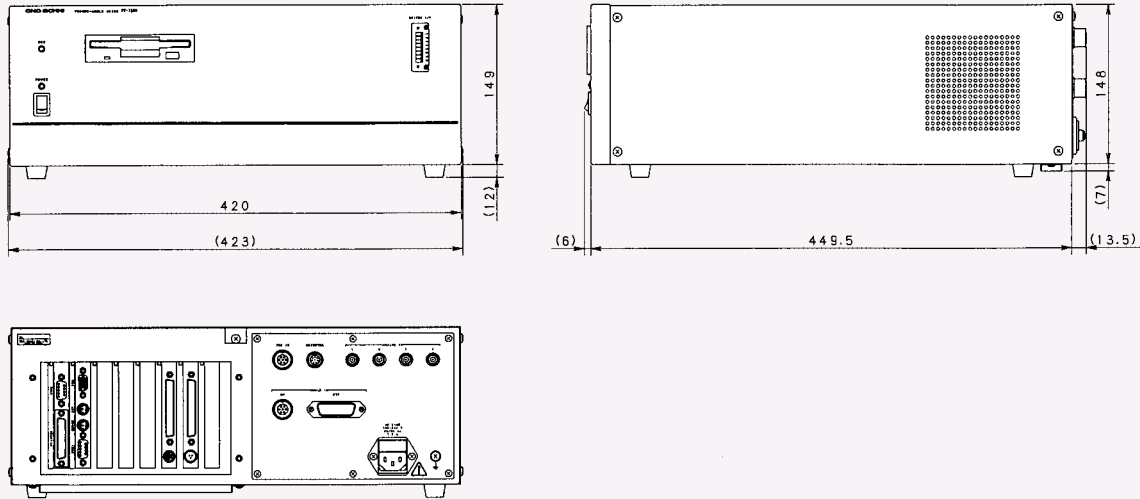

● PK Series

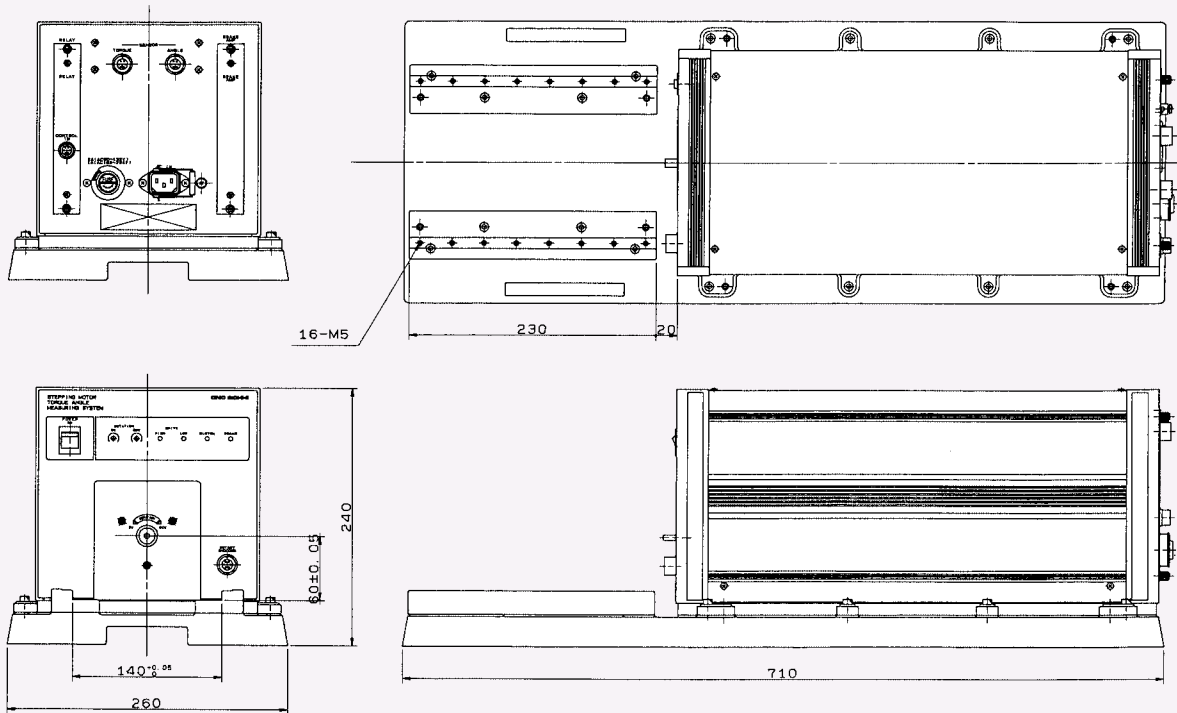

**ONO SOKKI**

**U.S.A. & CANADA**  
 Ono Sokki Technology Inc.  
 2171 Executive Drive, Suite 400  
 Addison, IL. 60101  
 U.S.A.  
 Phone: 630-627-9700  
 Fax : 630-627-0004

**EUROPE**  
 Ono Sokki Mess-und  
 Kontrollsysteme GmbH  
 Im Vogelsang 1, D-71101 Schoenaich  
 Germany  
 Phone: 07031-630203  
 Fax : 07031-654249

**P.R.CHINA**  
 Ono Sokki Beijing Office  
 Beijing Jing Guang Center 3510  
 Hu Jia Lou, Chao Yang Qu  
 Beijing P.R.C. 100020  
 Phone: 010-6597-3113  
 Fax : 010-6597-3114

**WORLDWIDE**  
 Ono Sokki Co., Ltd.  
 1-16-1 Hakusan, Midori-ku,  
 Yokohama 226-8507, Japan  
 Phone: 045-935-3976  
 Fax : 045-930-1906  
 E-mail: overseas@onosokki.co.jp

\*Outer appearance and specifications are subject to change without prior notice.

HOME PAGE: <http://www.onosokki.co.jp/English/english.htm>