

## Non-contact Speedometers

# LC Series



The LC-series is on-vehicle type of non-contact, non-marking speed measurement system with high accuracy. High-speed tests up to a maximum 320 km/h can be performed by LC-5200 System.

# LC-1100/2100

## Spatial filter type speed detectors

*The LC-1100/2100 spatial filter type speed detectors are designed exclusively for use with the LC Series non-contact speedometers.*

*The LC-1100 is designed for use with the LC-5200/761 systems, and features a mid-speed to high-speed measurement range from 1.5 km/h to 320 km/h.*

*The LC-2100 can measure speeds in both the positive and negative directions, including zero speed. It is designed for use with the LC-761 system, and can measure lateral direction speeds and low straight-line speeds in the range from -20 to +20 m/s (-72 to +72 km/h).*



### Explanation of the Measurement Principles

#### Extraction of Specific Unevenness in the Reflection

The spatial filter type speed detector is a very special sensor that extracts only specific unevenness in the reflection (uneven color, uneven surface, and so forth), from the irregular patterns formed by particles of various sizes such as small stones, sand, and asphalt on the road surface and railroad tracks, and patterns formed by tire marks.

To be more specific, from the irregular pattern on the road surface, only those components that are arranged in a regular sequence at 2.3 mm intervals are located. The fluctuations in the amount of reflected light generated by these components are converted to electrical signals and sent to the speedometer where the signals are passed through a bandpass filter, shaped into a waveform, converted to a pulse train, and calculated. Accordingly, since the signals were generated from the unevenness in the reflection at 2.3 mm intervals, the speed and the distance can be obtained by multiplying the values calculated in the specified time by 2.3 mm.

#### Converting a Photoelectric Current into an Easy-to-Understand Signal

Now, why is it that we can only extract the unevenness in the reflection that occurs at regular 2.3-mm intervals? The surface pattern of the road surface is passed through the objective lens and the slit, and an image is formed on top of the special light-receiving elements of the comb-shaped structure which acts as a spatial filter. Furthermore, as the vehicle that is being measured moves, variations in the photoelectric current occur.

Comparatively small amounts of unevenness in the reflection with respect to the lattice spacing pitch are averaged out with the large amounts of unevenness in the reflection by the "comb-shaped structure", and, depending on the differential effects from the pair of elements, the variations in the photoelectric current are almost cancelled out. By the way, getting back to the unevenness in the reflection (2.3-mm interval), large variations to the photoelectric current occur at each of the elements in the pair, and, on top of that, since a half-phase shift occurs, the variations cannot cancel each other out. That is to say, this is why only the specific unevenness in the reflection (unevenness every 2.3 mm) that is determined by the element structure and the optical system can be extracted for the extracted signal.

In addition, with the LC-2100, electrical processing is used to apply a frequency shift with respect to the detection signal obtained from the spatial filter, thereby enabling the extraction of a speed signal in the positive direction.

LC-1100/2100 Cross-section

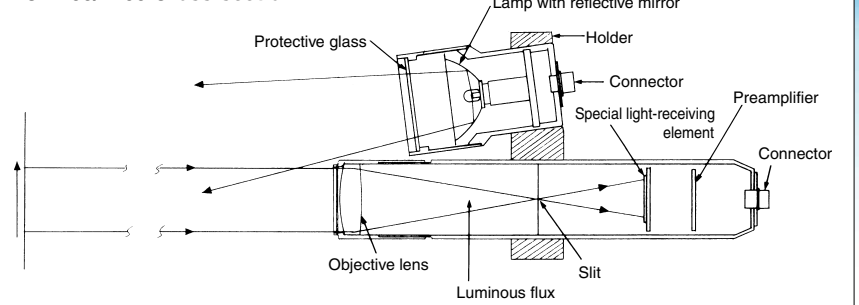

Photoelectric current spectrum (LC-1100)

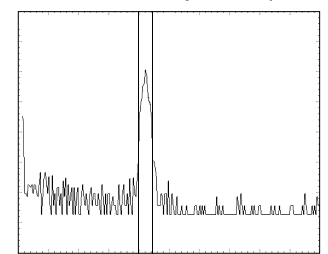

Average frequency extracted by the tracking filter

Figure illustrating the theory (LC-1100)

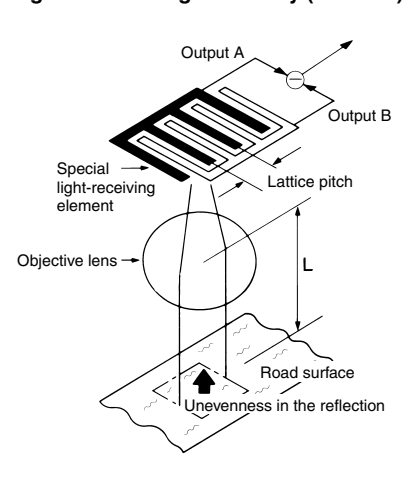

LC-1100/2100

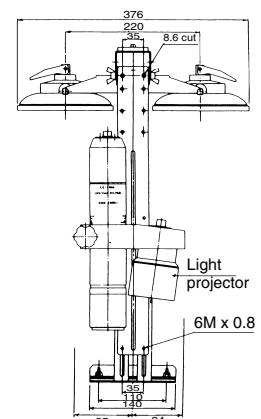

# LC-5200 System

For mid-speed to high-speed tests

System Configuration : LC-1100  
LC-5200

*Can handle high-speed tests up to a maximum of 320 km/h. High-performance, attaché-case type device with a built-in printer; can also perform fuel consumption tests.*

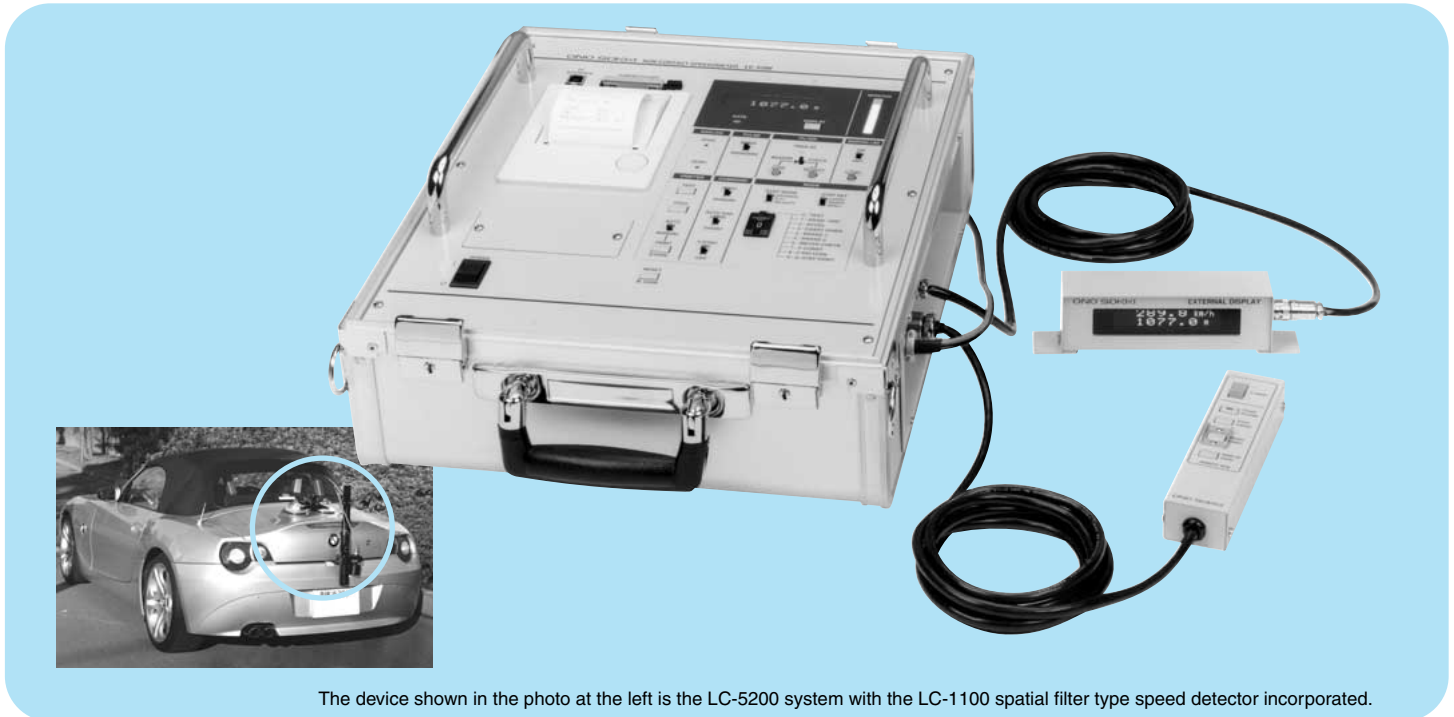

The device shown in the photo at the left is the LC-5200 system with the LC-1100 spatial filter type speed detector incorporated.

## Features

- Easy-to-read fluorescent display tube used in the display
- Selectable display pattern to suit the test conditions (single-row or double-row display)
- Built-in printer enables easy output of data
- The measurement data can be saved to a compact flash memory card
- Ten test modes provided
- Compact design

\* FP Series Volumetric Type Flow Detector is required to perform the test mode No. 7 & 8.

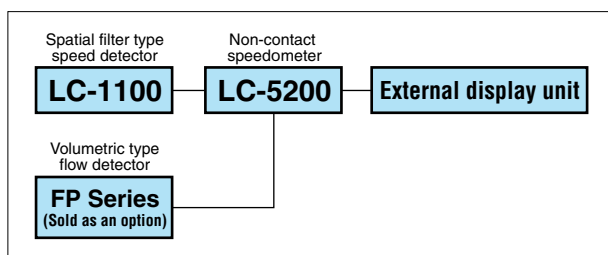

No.	Test MODE	Test Description	Measurement Units, Other	
			Speed Step	Distance Step, Other
0	TEST (Calibration and equipment testing)	Measurement of the distance, time, and average speed from GATE ON to GATE OFF (white line detection possible)		
1	SS400-1000 (Standing-start acceleration test)	Measurement of the distance, time, and section acceleration rate from the vehicle's standing-start position up to the 400-m or 1000-m position	Switched every 5 km/h 10 km/h 20 km/h	Switched every 25 m (50 m after 100 m) 50 m (100 m after 200 m) 100 m (200 m after 400 m)
2	ACCEL. (Passing acceleration test)	Measurement of the distance, time, and section acceleration rate from GATE ON (JUST speed function enabled) up to the 400-m or 1000-m position		Switched every 25, 50, 100 m
3	COAST DOWN (Coast-down test)	Measurement of the coast-down time and the coast-down coefficient from GATE ON (JUST speed function enabled) up to the 400-m or 1000-m position		(Calculates and displays MFDD)
4	BRAKE-1 (Brake test 1)	Measurement of the initial speed at the braking start time point and the braking distance, time, and average deceleration until the stopping point	Measures deceleration using STEP DATA	
5	BRAKE-2 (Brake test 2)	Measurement of the initial speed at the braking start time point and the braking distance, time, and section deceleration until the stopping point	Switched every 5, 10, 20 km/h	Switched every 5, 10, 20 m
6	METER CHECK (Meter calibration)	Comparison of the vehicle's speedometer with the actual speed		Desired number of times measured
7	F-CONST. (Constant fuel consumption test)	Measurement of the amount of fuel consumption and the fuel consumption rate from GATE ON up to the 500-m or 1000-m position		Switched every 100, 500, 1000 m
8	F-PATTERN (Fuel consumption pattern test)	Measurement of the amount of fuel consumption and the fuel consumption rate while changing the running pattern		Auto GATE OFF possible after 2 or 5 patterns
9	D. STEP PRINT (Fixed distance)	Continuous printing of the distance, time, and instantaneous speed from GATE ON (white line detection possible) to GATE OFF		Switched every 50, 250, 500 m

# LC-761 System

For Sideslip Testing

System Configuration : LC-761  
LC-1100  
LC-2100

*Simultaneous measurement of the straight-line speed, lateral speed, and the sideslip angle.  
Optimal system for operational and stability tests.*



Note: Spatial filter type speed detectors (LC-1100/2100) are included in the LC-761 system, but not shown in the above photograph.

The LC-761 Sideslip Testing System measures the vehicle's speed with respect to the ground and the sideslip angle. Since it outputs the vehicle's straight-line speed, lateral speed, and sideslip angle, the motion aspects during operational and stability tests can be continuously monitored. The LC-1100 detector is designed for the measurement of straight-line speeds, and the LC-2100 for the measurement of lateral speeds. Minute detector mounting angle errors have appeared until now as large speed error components in the measurement of vehicle lateral speeds. With the LC-761 system, an auto correction function is provided to correct any mounting angle error in the LC-2100 and thereby ensure accurate lateral speed measurement. Moreover, since the distance pulse output from the LC-5200 can be input as a straight-line speed signal, measurement of the sideslip angle can be performed while saving the straight-line speed data to the LC-5200's memory.

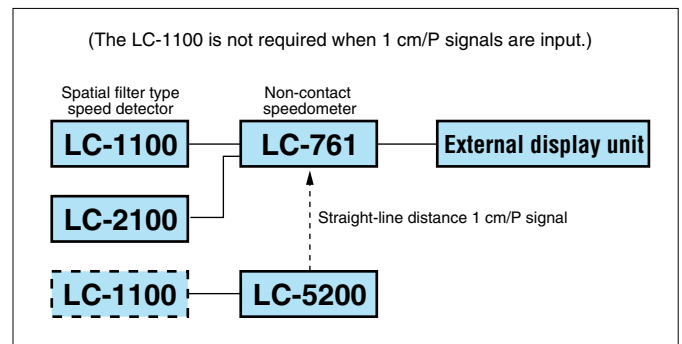

# Options

For the LC Series



FP-2140H

## FP Series Volumetric Type Flow Detectors<sup>\*1</sup>

The FP Series flow detectors are compact, lightweight volumetric-type flow meters that are ideal for in-vehicle mounting. Three measurement ranges are provided: 0.06 to 60 l/h, 0.3 to 120 l/h, and 1 to 1440 l/h. Fuel quantities from micro-capacity flows during idling through to large-capacity flows under high-speed, high-load conditions can be measured. Moreover, a function for detecting the direction of rotation compensates for errors caused by pulsating or back flows enables highly accurate measurement within  $\pm 0.2\%$  or  $\pm 0.5\%$  of the reading.

Compatible models : LC-5200 system (FP-213/2140H/215)

Measurement ranges : 0.06 to 60 l/h (FP-213)  
0.3 to 120 l/h<sup>\*2</sup> (FP-2140H)  
1 to 1440 l/h (FP-215)

Accuracy : Within  $\pm 0.2\%$  of reading (FP-2140H)  
Within  $\pm 0.5\%$  of reading (FP-213/215)

Applicable fluids : Gasoline, light oil, kerosene

Note: <sup>\*1</sup> The signal cable is sold separately.

<sup>\*2</sup> Can be modified to 0.3 to 200 l/h upon request

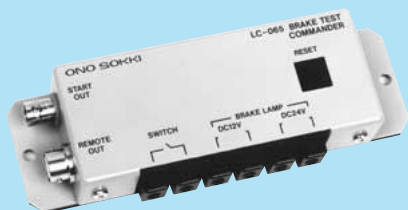

LC-065

## LC-065 Brake Test Commander

When a braking test is performed, the LC-065 inputs a voltage signal (12 or 24 VDC) from the brake lamp and a non-voltage 1a contact signal from the tape switch (provided) or other source, and outputs an external start signal for the LC Series. This enables a voltage input from the vehicle's brake lamp to be added to the non-voltage 1a contact signal.

Compatible models : LC-761 system

Input signals : Non-voltage 1a contact signal and a voltage signal  
(12 or 24 VDC)

Operating temperature range : 0 to +50°C

Outer dimensions : 160 (W) x 30 (H) x 58 (D) mm

Weight : Approx. 200 g



SF-061

## SF-061 Carrying case for the LC-1100/2100 models

The SF-061 carrying case holds the LC-1100/2100 detector already mounted on its mounting fixture, together with accessories such as the external display unit, remote box, cables, and so forth. Accordingly, only two items are required to be taken to the measurement site: the LC Series main unit and the SF-061 carrying case. Moreover, the carrying case is useful for shipping the equipment to remote sites, and for storing the equipment when it is not in use.

Compatible models : LC-1100/2100

Material : FRP (fiber-reinforced plastic)

Casters : Four rotating caster wheels

Outer dimensions : 530 (W) x 530 (H) x 230 (D) mm

Weight : Approx. 7 kg

## LC-0001A Halogen lamp for LC-1100/2100

The LC-0001A is a replacement halogen lamp for the light projector used in the LC-1100/2100 detectors.

Compatible models : LC-1100/2100

Standard : 12 VDC 50 W (4.2 A) halogen lamp

## PU-206 Recording paper for use with a printer

PU-206 : For the LC-5200 (10 rolls/box)

## ■ Non-contact Speedometer Specifications

Specification	Model name	LC-5200
Measurement range		1.5 to 320 km/h
Overall accuracy		
Speed		±0.5%
Distance		±0.1% STD (when 400 m or longer)
Built-in display unit		Fluorescent display tube (speed, distance, and simultaneous display of these two parameters)
Display parameter setting range		(varies slightly according to the mode selected)
Speed		4 digits 0.1 to 320.0 km/h
Distance		6 digits 0.0 to 99999.9 m
Time		6 digits 0.00 to 9999.99 s
Fuel rate		4 digits 0.00 to 99.99 km/l
External display unit		Speed, distance, and simultaneous display of these two parameters
Speed display time		0.5 s automatic repeat
Analog output section		
Speed		0 to +6.4 V/0 to 320 km/h
Linearity		Within ±0.2% of full scale
Response		Approx. 0.04, 0.3 s automatically switched
Pulse output section		
Distance		1 cm/P
Level		TTL (22 kΩ load or higher)
Start/stop signals		Auto (Standing-start, speed, distance, stop coherence method) Manual operation, external input, white line detection, brake lamp input
Memory capacity		Approx. 15,000 steps
CF memory		Type I
Format method		FAT format
Memory format		Measurement data is saved in the CSV format.
Test modes		
0 TEST		Calibration and equipment performance check tests
1 SS400-1000		Standing-start acceleration test
2 ACCEL		Passing acceleration test
3 COAST DOWN		Coast-down test
4 BRAKE-1		Braking test (MFDD)
5 BRAKE-2		Braking test (speed STEP)
6 METER CHECK		Meter check
7 F-CONST		Constant fuel consumption test
8 F-PATTERN		Fuel consumption pattern test
9 D.STEP PRINT		Continuous print-out for each distance
Printing method		Thermal dot matrix
Printing speed		Approx. 2 lines/second
Recording section		
Speed		4 digits
Distance		6 digits
Time		6 digits
Acceleration		4 digits
Accumulated flow		6 digits
Fuel consumption rate		4 digits
Recording method		Switched between AUTO and MANUAL
Other functions		Fixed format for each test
Input pulse (flow)		FP series, 0.1 ml/P
Input pulse (distance)		1 cm/P
Power supply		10 to 15 VDC
Power consumption		Approx. 8 A (including light projector current)
Operating temperature range		0 to +50°C
Outer dimensions		330 (W) x 160 (H) x 350 (D) mm
Weight (excluding detector)		Approx. 7.5 kg

Specification	Model name	LC-761
Measurement range		
Straight-line speed		1.5 to 250 km/h
Lateral speed		-20 to +20 m/s
Sideslip angle		0 to ±25°
Overall accuracy		
Speed		±0.5%
Distance		±0.1% STD (when the straight line is 400 m or longer)
Built-in display unit		Red LEDs
Display parameter setting range		
Straight-line speed		4 digits 000.0 to 250.0 km/h
Lateral speed		Polarity + 4 digits 00.00 to ±20.00 m/s
Straight-line distance		5 digits 0000.0 to 9999.9 m
Lateral distance		Polarity + 4 digits 000.0 to ±999.9 m
Display method		The straight-line speed and lateral direction distance are switch-selectable. The straight-line distance and lateral direction speed are switch-selectable.
External display unit		
Straight-line speed		4-digit LCD, 0.0 to 250.0 km/h
Sideslip angle		Analog meter display (0 to ±25°)
Speed display time		0.5 s automatic repeat
Analog output section		
Straight-line speed		0 to +5.0 V/0 to 250 km/h
Lateral speed		0 to ±10.0 V/0 to ±20 m/s
Sideslip angle		0 to ±12.5 V/0 to ±25°
Linearity		Within ±0.2% of reading
Response		Approx. 0.08 s (straight-line speed)
Pulse output section		
Distance		1 cm/P (always output)
Time		1 s/P (Only output for GATE ON)
Level		TTL (10 kΩ load or higher)
Start/stop signals		Manual operation, external input, white line detection
Auto correction functions		Auto correction of the LC-2100 mounting angle error (torsional angle) (the correctable range is within ±5°, but only up to 200 km/h)
Power supply		10 to 15 VDC
Power consumption		Approx. 12 A (includes the whole system)
Operating temperature range		0 to +50°C
Outer dimensions		335 (W) x 110 (H) x 420 (D) mm
Weight (excluding detector)		Approx. 9 kg

## ■ Spatial Filter type Speed Detector Specifications

Specification	Model name	LC-1100
Speed measurement range		1.5 to 320 km/h (When the radius is 10R or higher at a level surface on the test course)
Detector mounting height		500 ±100 mm (height between the measurement surface and the detector tip)
Detector mounting angle		0° ±3° (torsional angle), 90° ±3° (forward direction), 90° ±10° (diagonal angle)
Measurement area		Approx. 46 mm x 60 mm (forward direction x vehicle width direction)
Light projector		12 VDC, 50 W (4.2A) Life: Approx. 400 hours of continuous use
Outer dimensions		Approx. 179 (W) x 330 (H) x 88 (D) mm (excluding the mounting fixture)
Weight		Approx. 1.6 kg (when the mounting fixture is excluded) Approx. 5.2 kg (when the mounting fixture is included)

Specification	Model name	LC-2100
Speed measurement range		-20 to +20 m/s (-72 to +72 km/h)
Detector mounting height		500 ±70 mm (height between the measurement surface and the detector tip)
Detector mounting angle		0° ±3° (torsional angle), 90° ±5° (forward direction), 90° ±3° (diagonal angle)
Measurement area		Approx. 50 mm x 50 mm (forward direction x vehicle width direction)
Light projector		12 VDC, 50 W (4.2A) Life: Approx. 400 hours of continuous use
Outer dimensions		Approx. 179 (W) x 330 (H) x 88 (D) mm (excluding the mounting fixture)
Weight		Approx. 1.6 kg (when the mounting fixture is excluded) Approx. 5.2 kg (when the mounting fixture is included)

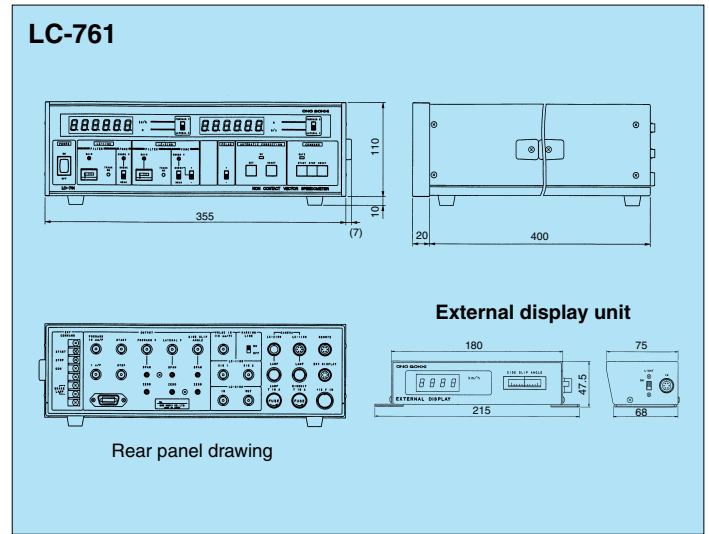
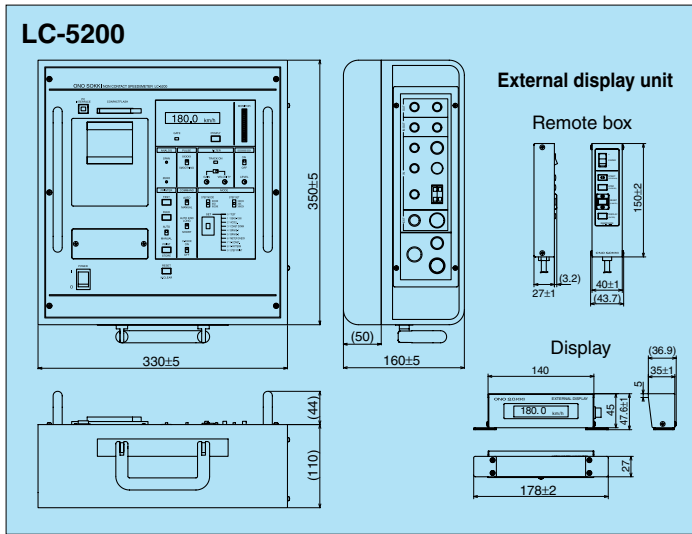

# LC Series Related Products

## ■ Non-contact Detectors

### LC-3110/3210

*These detectors were developed as lightweight, low-cost counterparts to the LC-1100/2100 detectors.*

*The LC-3110 is a straight-line direction speed detector, and the LC-3210 is a lateral direction speed detector.*



### Detector Specifications

Specification	Model name	LC-3110
Measurement range		-120 to +390 km/h
Detector mounting height		280 ±60 mm (height between the measurement surface and the detector tip)
Distance resolution		10 mm/P
Pulse output		10 mm/P (TTL), 90° differential phase signal
Analog output		±20 mV/±1 km/h DC
White line detection signal		Analog signal (0 to 12 V DC)
Stop signal		TTL signal (Hi when stopped)
Light projector		12 VDC, 50 W (Life: Approx. 400 hours of continuous use)
Operating temperature range		-10 to +40°C
Outer dimensions		180 (W) x 150 (H) x 88 (D) mm
Weight		Approx. 1.7 kg LC-0130 mounting fixture (option): Approx. 3.1 kg

Specification	Model name	LC-3210
Measurement range		-108 to +108 km/h
Detector mounting height		280 ±60 mm (height between the measurement surface and the detector tip)
Distance resolution		10 mm/P
Pulse output		10 mm/P (TTL), 90° differential phase signal
Analog output		±83.3 mV/±1 km/h DC
Light projector		12 VDC, 50 W (Life: Approx. 400 hours of continuous use)
Operating temperature range		-10 to +40°C
Outer dimensions		180 (W) x 150 (H) x 88 (D) mm
Weight		Approx. 1.7 kg LC-0130 mounting fixture (option): Approx. 3.1 kg

# ■ Non-contact Speedometer/Odometer Set

*This set combines the non-contact LC-3110 speed detector with a display unit to enable easy speed and running distance measurement as well as braking tests.*

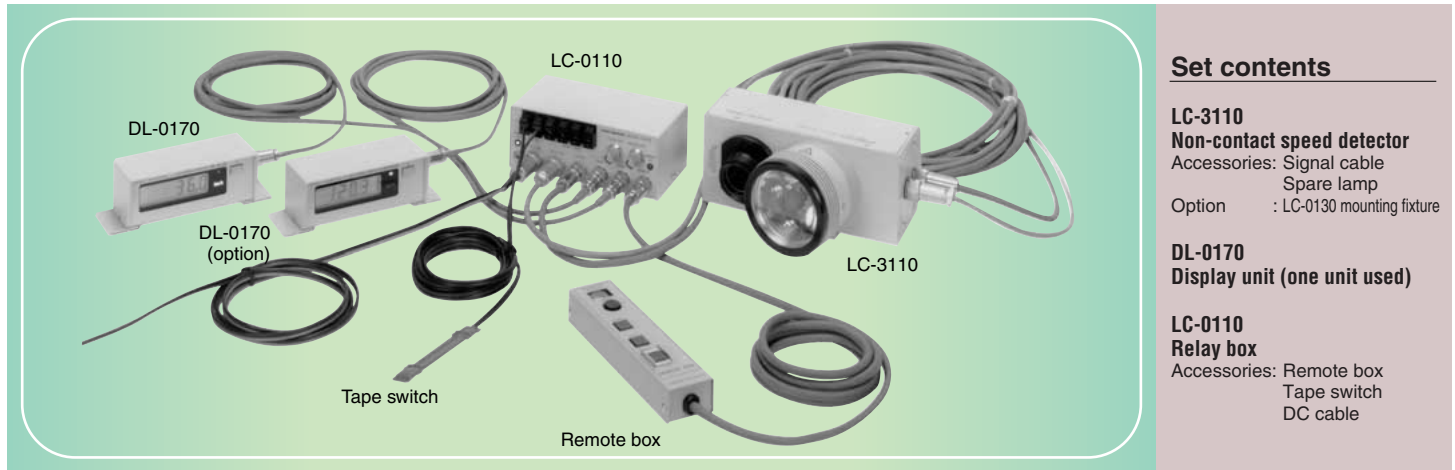

## Set contents

- LC-3110**  
**Non-contact speed detector**  
 Accessories: Signal cable  
 Spare lamp  
 Option : LC-0130 mounting fixture
- DL-0170**  
**Display unit (one unit used)**
- LC-0110**  
**Relay box**  
 Accessories: Remote box  
 Tape switch  
 DC cable

## ■ LC-0110 Relay Box

- The LC-0110 is a relay box that was developed exclusively for use with the LC-3110, and features a built-in control circuit for displaying the speed and distance.
- BNC connectors are used for the speed analog output and distance pulse output (10 mm/P) functions to enable simplified wiring.
- Adding a further DL-0170 display unit (this is an optional setting) enables brake testing to be performed. The brake start speed's holding and braking distances are displayed.

## Relay Box Specifications

Specification	Model name	LC-0110
Output	PULSE OUT	BNC connectors used for pulse and analog output from the LC-3110
	ANALOG OUT	
	DISP1	Used for output from the DL-0170 display unit only
	DISP2	Used for output from the DL-0170 display unit only
Input	12VDC	LC-3110 current output
	LC-3110	Signal input from the LC-3110
	REMOTE	For distance measurement; can also be used for white-line detection
	SWITCH	Start switch for the braking test
	BRAKE LAMP	Brake lamp input
	12VDC	9 to 16 VDC IN Max. 10 A
Outer dimensions		150 (W) x 60 (H) x 80 (D) mm
Weight		Approx. 500 g
Accessories		Remote box (cable provided), tape switch, DC cable, spare fuse

## ■ DL-0170 Display unit

- If 5 VDC circuit, 10 mm/P, measurement gate signals or reset signals are input, the displays shown in the table at the right are enabled.

## Display Unit Specifications

Specification	Model name	DL-0170
Display selection		Display contents 0.0 km/h
DIP switches		0.00m 6 digits (zero blanking)
All OFF		Speed display (0.36s gate)
1-ON		Holds the measurement start time speed
2-ON		Speed display of the 0.72s gate
3-ON		Distance display
4-Always OFF		-
Current consumption		200 mA 5V
Outer dimensions		120 (W) x 45 (H) x 55 (D) mm
Weight		Approx. 230 g

\*Outer appearance and specifications are subject to change without prior notice.

URL: <http://www.onosokki.co.jp/English/english.htm>

**ONO SOKKI**

### U.S.A. & CANADA

Ono Sokki Technology Inc.  
 2171 Executive Drive, Suite 400  
 Addison, IL. 60101 U.S.A.  
 Phone: 630-627-9700  
 Fax : 630-627-0004  
 URL : <http://www.onosokki.net>  
 E-mail : [info@onosokki.net](mailto:info@onosokki.net)

### P.R.CHINA

Ono Sokki Beijing Office  
 Beijing Jing Guang Center 3510  
 Hu Jia Lou, Chao Yang Qu  
 Beijing P.R.C. 100020  
 Phone: 010-6597-3113  
 Fax : 010-6597-3114  
 E-mail : [onosokki@public.bta.net.ch](mailto:onosokki@public.bta.net.ch)

### WORLDWIDE

Ono Sokki Co., Ltd.  
 1-16-1 Hakusan, Midori-ku,  
 Yokohama 226-8507, Japan  
 Phone: 045-935-3976  
 Fax : 045-930-1906  
 E-mail: [overseas@onosokki.co.jp](mailto:overseas@onosokki.co.jp)