

High Resolution Linear Gauge Sensor

HS-3412/3425

High Resolution Digital Gauge Counter

HG-4370



- *Best suitable as a high precise positioning detector because of high accuracy ($\pm 0.5\mu\text{m}$) and high resolution ($\pm 0.05\mu\text{m}$)*
- *Proof structure against dust (Protection class: IP50 of environmental resistance)*
- *Large size LEDs (Character height: 14mm) as displaying device are used for easy data reading.*
- *Various function of offset/peak hold (MAX., MIN., RANGE)/multiplying and selection of resolution ($0.05\mu\text{m}/0.1\mu\text{m}/0.5\mu\text{m}$)*

ONO SOKKI

HS-3412/3425 High Resolution Linear Gauge Sensor

Unit : mm

	HS-3412	HS-3425
Measuring range	12 mm	25 mm
Resolution		0.05 μ m
Displaying accuracy (at 20°C)		\pm 0.5 μ m
Measurement force (at downward)		0.6N
Protection class		IP50
Stem Diameter		ϕ 8 h 6 mm
Max. spindle speed*		0.2 m/s
Power supply		5DCV
Consumption current		20 mA Max.
Operating temperature		0 to 40°C
Cable length	Approx. 2 meter	
Weight	Approx. 200g	Approx. 220g
Accessories	Finger lift, Pin to replace the contact tip Spindle protection cap	

* It is maximum spindle speed when it is combined with exclusive counter of model HG-4370.

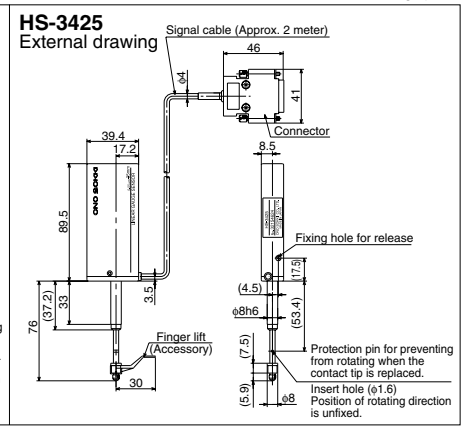
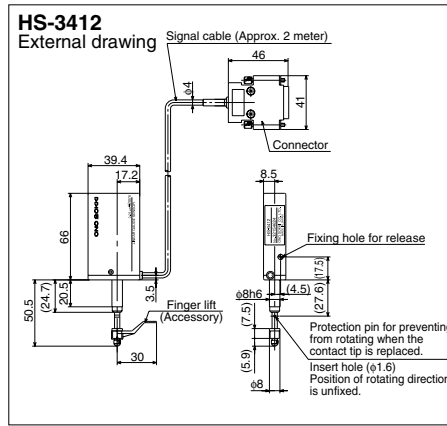

HG-4370 High Resolution Digital Gauge Counter

Unit : mm

■ Suitable sensor: Model HS-3412/3425

2-Phase difference signal, Sine waveform

■ Displaying section

MAIN	Displaying device 7-segment LED (Red color) Character height 14 mm
SUB	Displaying device LCD module No. of displayed characters 16-character x 2 lines
STATUS	Displaying the comparator result UPPER (Red), OK (Green), LOWER (Red)

■ Function

Selectable of resolution	Switchover at 0.05 μ m, 0.1 μ m, 0.5 μ m
Multiplying	Setting range : x 0.000001 to 9.99999
Offset	Measurement range : \pm 9999999
Peak hold	MAX., Min., RANGE (MAX.-MIN.)
Comparator	LO : LOWER set value \geq Measurement value OK : LOWER set value < Measurement value < UPPER set value UP : UPPER set value \leq Measurement value
	Signal output by photo coupler Max. capacity : DC30 V, 40mA Renewal time : Less than 30 ms

■ Control by external signal

Specification of input signal	Voltage input : Hi level: +4 to +5.25 V Lo level: 0 to +1 V Non-contact input : Open-circuit voltage ; 5.25V Max. Short-circuit current ; 1mA Max Input signal logic : Negative logic (Lo level or contact-close) Type of signal : Reset, Hold, Comparator, Peak hold
-------------------------------	--

■ External signal input

Recommended interface

The following circuit is recommended as the interface for the external signal input of RESET, HOLD, COMPARATOR, PEAK HOLD.

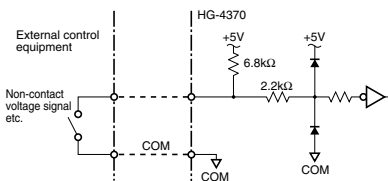

Voltage input	Hi level : +4 to +5.25 V Lo level : 0 to +1 V Open-circuit voltage : 5.25V Max. Short-circuit current : 1mA Max
Non-contact input	
Input signal logic	Negative logic (Lo level or contact-close)

■ RS-232C Interface

For data printing by DPU-414 exclusive printer and data communication with personal computer

Based on the EIA-RS-232C.

Baud rate | 2400/4800/9600 bps

■ General Specification

Consumption current	1A Max. (at 9VDC)
Operating temperature	0 to 40°C
Outer dimensions	144(W) x 72(H) x 180(D) mm
Weight	Approx. 1.5 kg

■ Accessories

Exclusive AC power adaptor	1 pc.
Stand foot	1 set
Rubber foot	1 set
Socket for terminal	1 pc. (10-pin)

■ Options

SH-022	Gauge stand
DPU-414	Exclusive digital printer (Signal cable to connect HG-4370 is provided as standard accessory.)
AX-5022	RS-232C Cable
AA-3301	Panel mount fixture
AA-813	Mechanical release
AA-916	Air release

HG-4370 External drawing

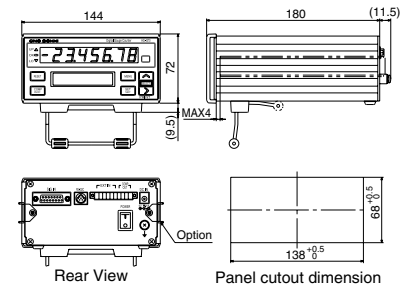

SH-022 External drawing

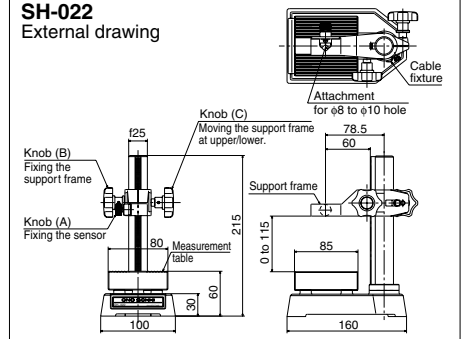

■ Connection to sequencer

Recommended interface

The following circuit is recommended as the interface for the external signal input of COMPARATOR.

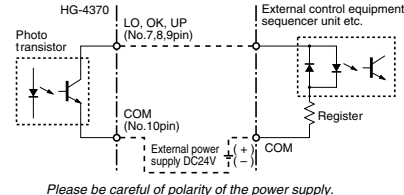

Signal output by photo coupler
Max. capacity : DC30 V, 40mA

Comparator function is working as following.
LO : LOWER set value \geq Measurement value
OK : LOWER set value < Measurement value < UPPER set value
UP : UPPER set value \leq Measurement value

* Outer appearance and specifications are subject to change without prior notice.

ONOSOKKI

URL: <http://www.onosokki.co.jp/English/english.htm>

U.S.A. & CANADA

Ono Sokki Technology Inc.
2171 Executive Drive, Suite 400
Addison, IL. 60101 U.S.A.
Phone : 630-627-9700
Fax : 630-627-0004
URL : <http://www.onosokki.net>
E-mail : info@onosokki.net

P.R.CHINA

Ono Sokki Beijing Office
Beijing Jing Guang Center 3510
Hu Jia Lou, Chao Yang Qu
Beijing P.R.C. 100020
Phone : 010-6597-3113
Fax : 010-6597-3114
E-mail : onosokki@public.bta.net.cn

WORLDWIDE

Ono Sokki Co., Ltd.
1-16-1 Hakusan, Midori-ku,
Yokohama 226-8507, Japan
Phone: 045-935-3976
Fax : 045-930-1906
E-mail: overseas@onosokki.co.jp



Recycled Paper

CAT. NO. 040904-01 Printed in Japan 04Y (SK) 2K