

Bolt attachment position (Viewed from direction B)

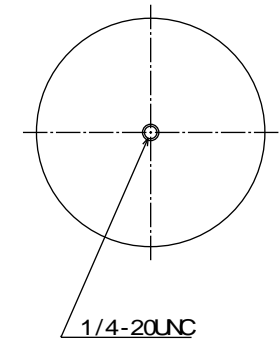
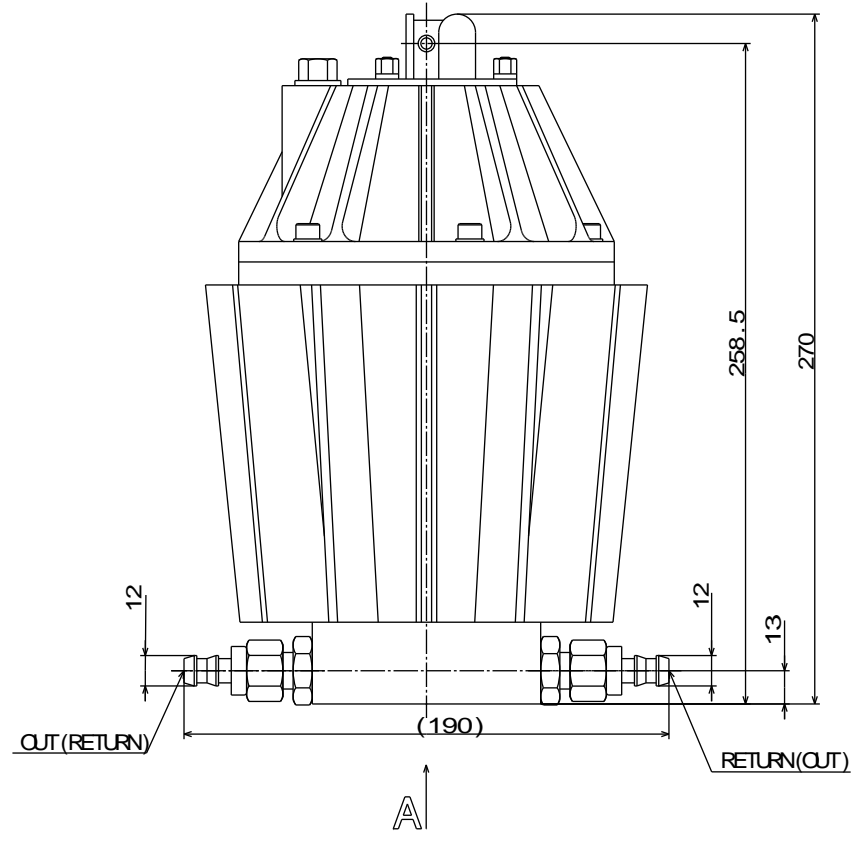

Bolt attachment position (Viewed from direction A)

- : Approx. 80 l/h (when the light oil is 15 and the inlet pressure is 0.5kg/cm²)
- : Approx. 250 l/h
- : 0.5kg/cm²
- : Light oil, gasoline
- : 1.2 l
- : 0.218²
- : 0.085 m²
- : 3.4kg