

Connecting the microphone extension cable between the main unit and preamplifier of LA-5560/5111 (Type I)

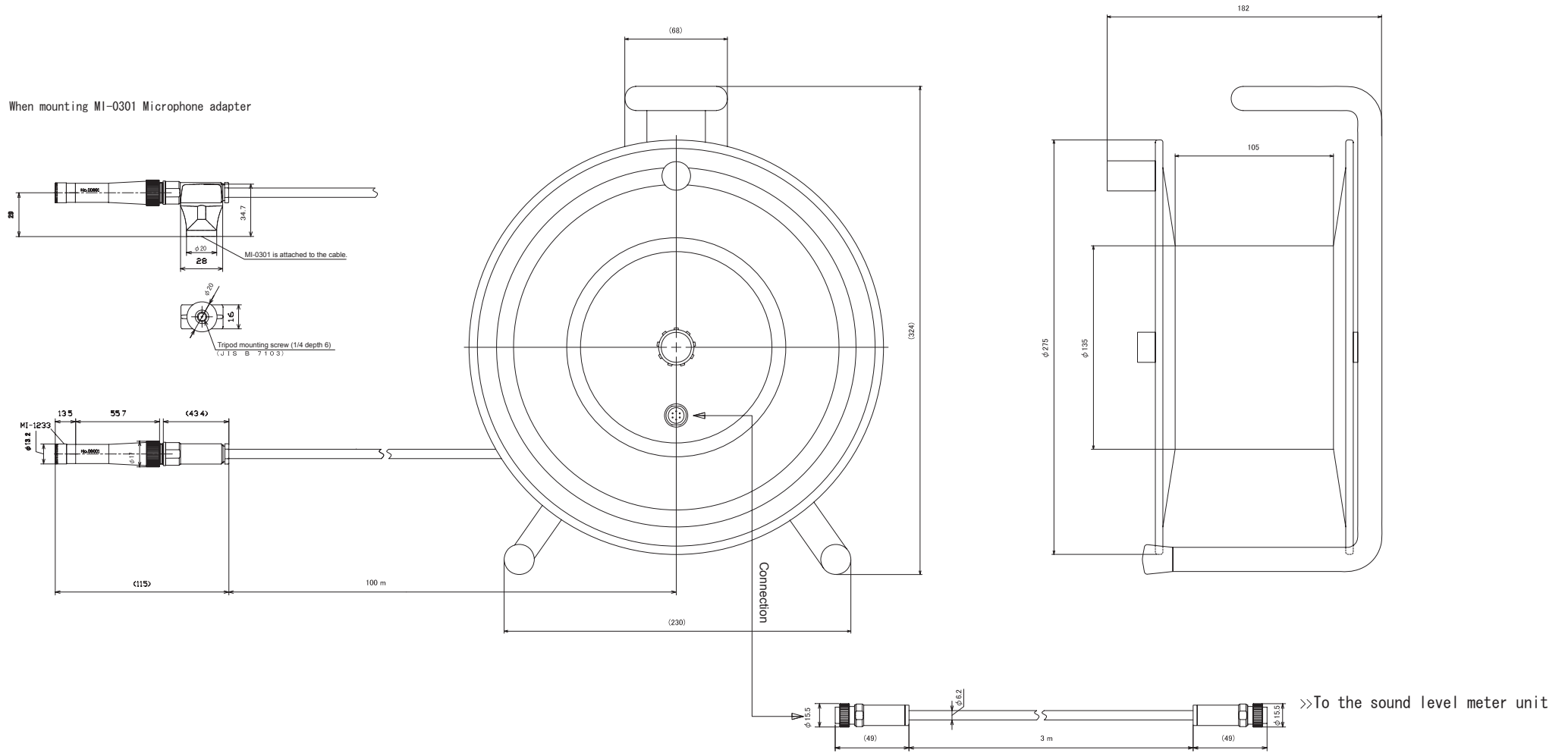

Weight: approx. 7.4kg (not including preamplifier) amplifier)